



# Kontrox™ 200mm Wafer Pilot Line, Passivation and Improved Interfaces for Compound Semiconductors & Optoelectronics



Elias Tsiatas  
Sales & Business Development Director

10 December 2024. 16:00 - 17:00 CET

## EPIC Members New Product Release



# Company Overview

- **Unique expertise** in compound semiconductor surface engineering
- **Proprietary technology** boosting the performance and manufacturability of compound semiconductors devices
- **Enhancing global environmental sustainability** by increasing the efficiency & manufacturing yields of billions of III-V devices



## Corporate Development

- **+ 50%** growth in 2024
- Team of 27 Year-to-Date



## Collaborations Across All Target Industries

- Power, RF,  $\mu$ LEDs, Lasers, Quantum, Substrates
- Major Multiyear Development Agreement



## State-of-the-Art LAB

- Several UHV Reactors + ISO5/6/7 Cleanroom
- Outstanding Characterization Capabilities



## Solutions and Business Model

- Passivation Technology for III-V compounds
- Technology Transfer : Equipment, IP License/Royalty



**Founded in 2017 : Spin-off from University of Turku, FINLAND**

# Kontrox™: Enhancing Deposition Methods' Efficiency & Performance

**BOTTLENECK** : Interfaces between III-V material and traditional thin films still present high defect density.

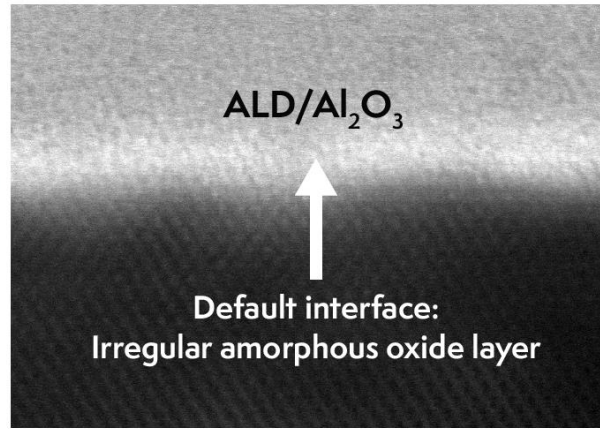
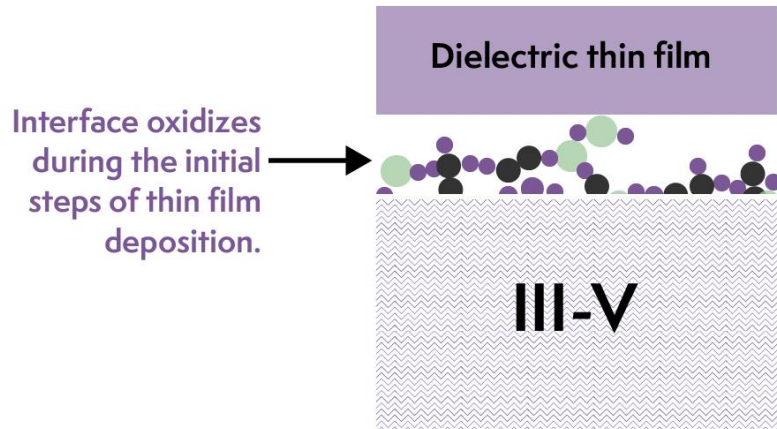

**Kontrox™** elevates coating performance:  
**Complementing and Enhancing Conventional Thin-film Methods (e.g. ALD, PECVD) for Next-Gen Compound Semiconductor Devices.**

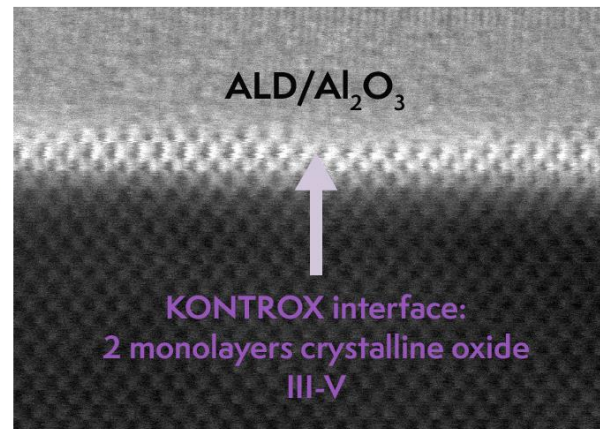
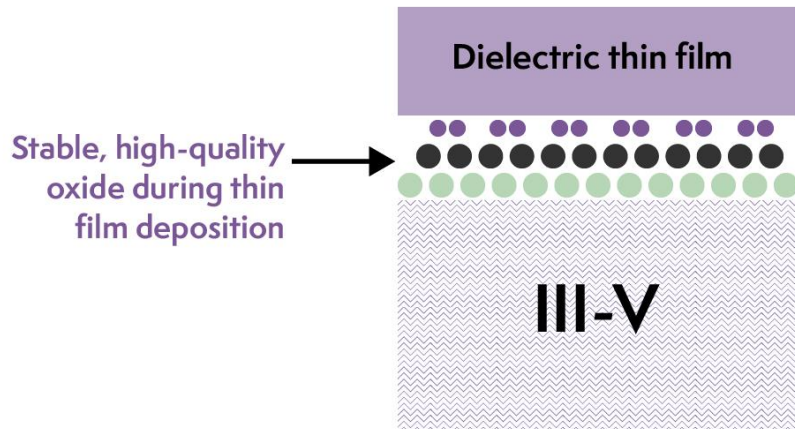

**Lower manufacturing costs / less waste**



**Making semiconductor industry more sustainable**

- **98% of surface defect reduction**
- **Stable** crystalline oxide structures
- Unprecedented **device performance**
- Higher manufacturing **yields**

# Applications for **Kontrox™** passivation

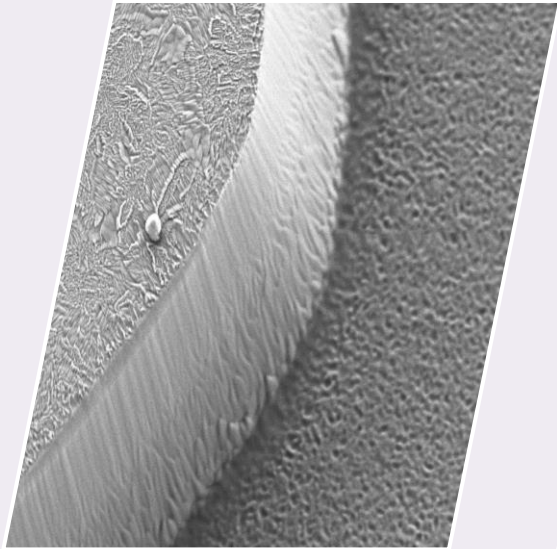

**Sidewalls**

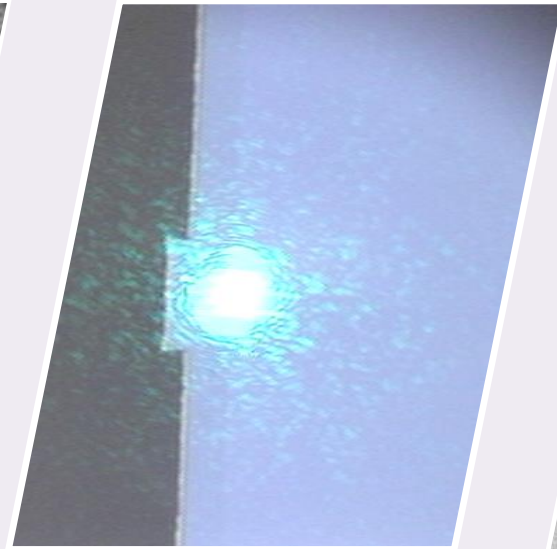

**Laser Facets**

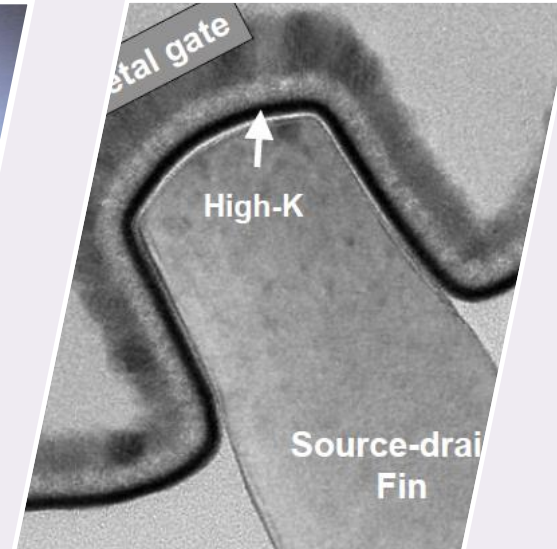

**Interfaces**



**Substrates**



GaAs  
GaP

AlGaAs  
InGaAlP

InAs  
GaN

InGaAs  
InGaN

InAlGaAs  
AlGaN & more

InP

GaSb

InSb

InGaP

# Kontrox™ Transistors : Interface (Al)GaN

Cleaned GaN(0001)(1x1)

Kontrox GaN(0001)(3√3x3√3) – R30°

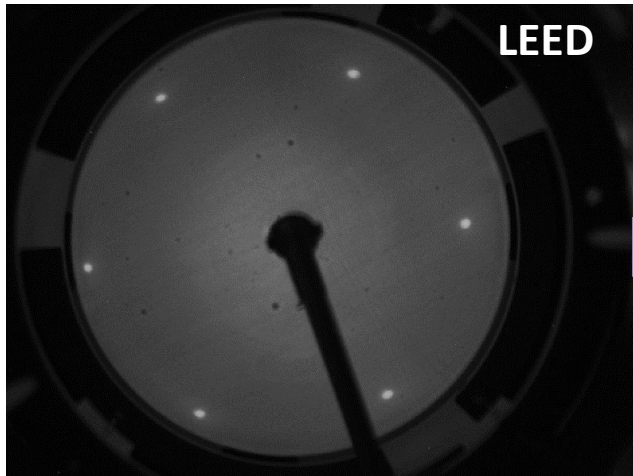

LEED

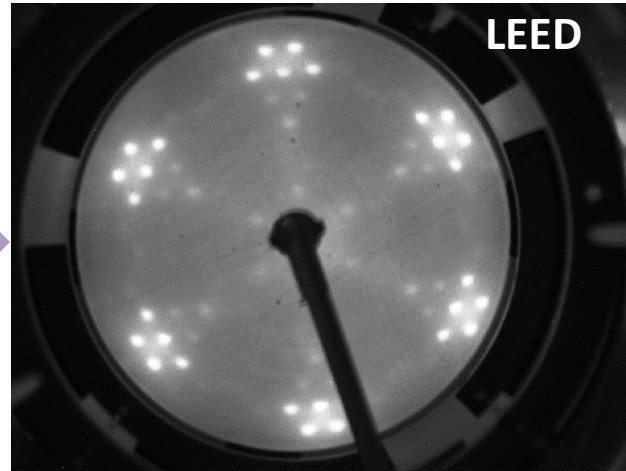

LEED

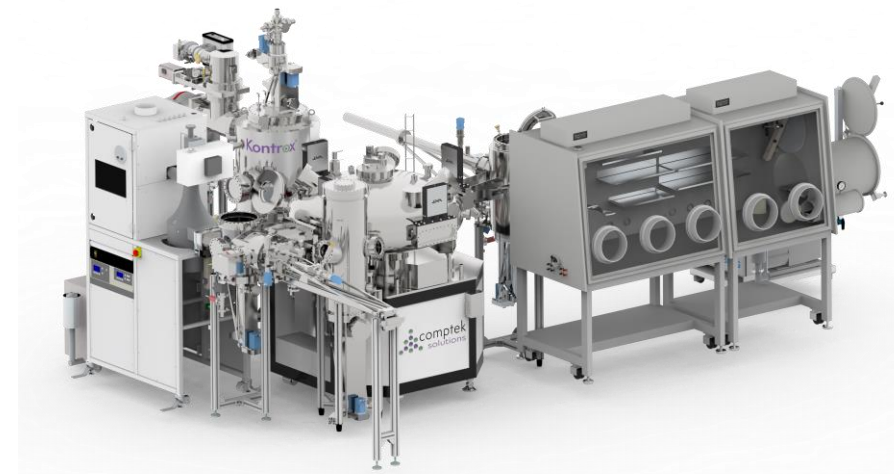

- Very well defined Kontrox crystalline oxide
- GaN(0001)(3√3x3√3) – R30° structure
- Good stability towards air exposure

Kontrox™ helps improve electrical characteristics of GaN materials & interfaces

- Reducing density interface traps (DIT)
- Increasing electron mobility

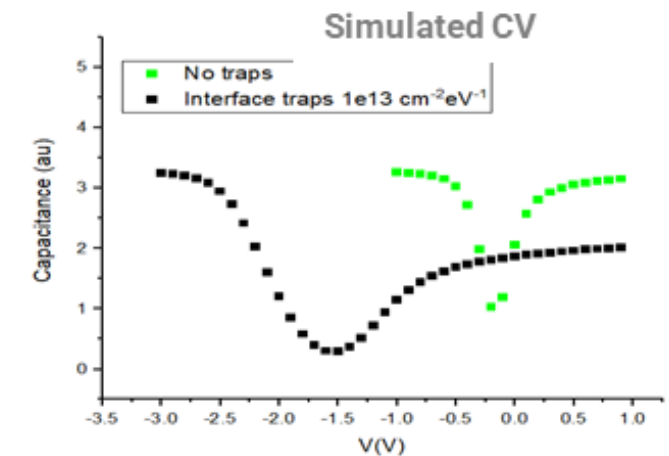
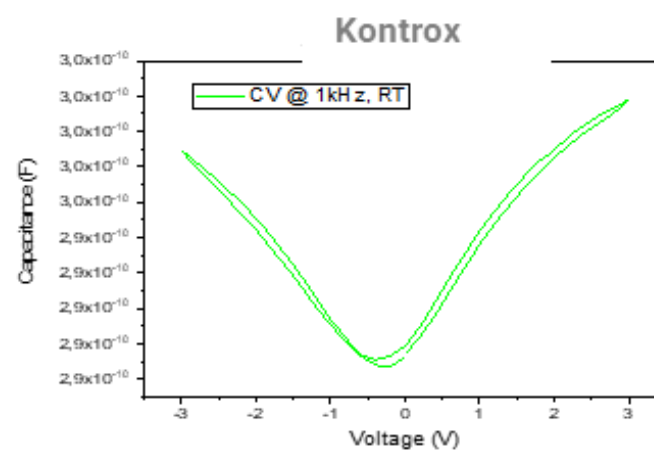
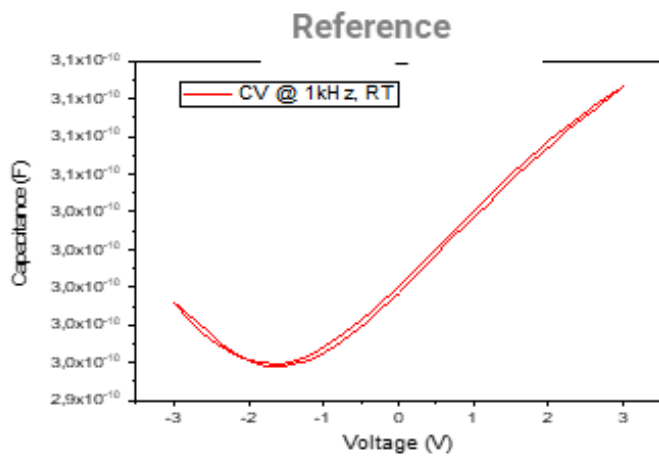

# Kontrox™ Photonics : Lifetime (EEL)

- LASE16™ : ZnSe quality at a fraction of the cost
- Outstanding improvements after extended air exposure prior to mirror coatings

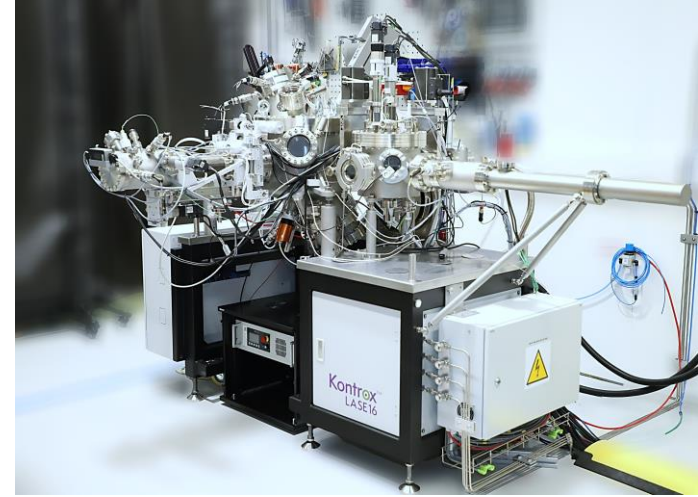

Kontrox @Comptek + Mirror coatings @ CUSTOMER  
Up to 100% improvement in high Power pulse

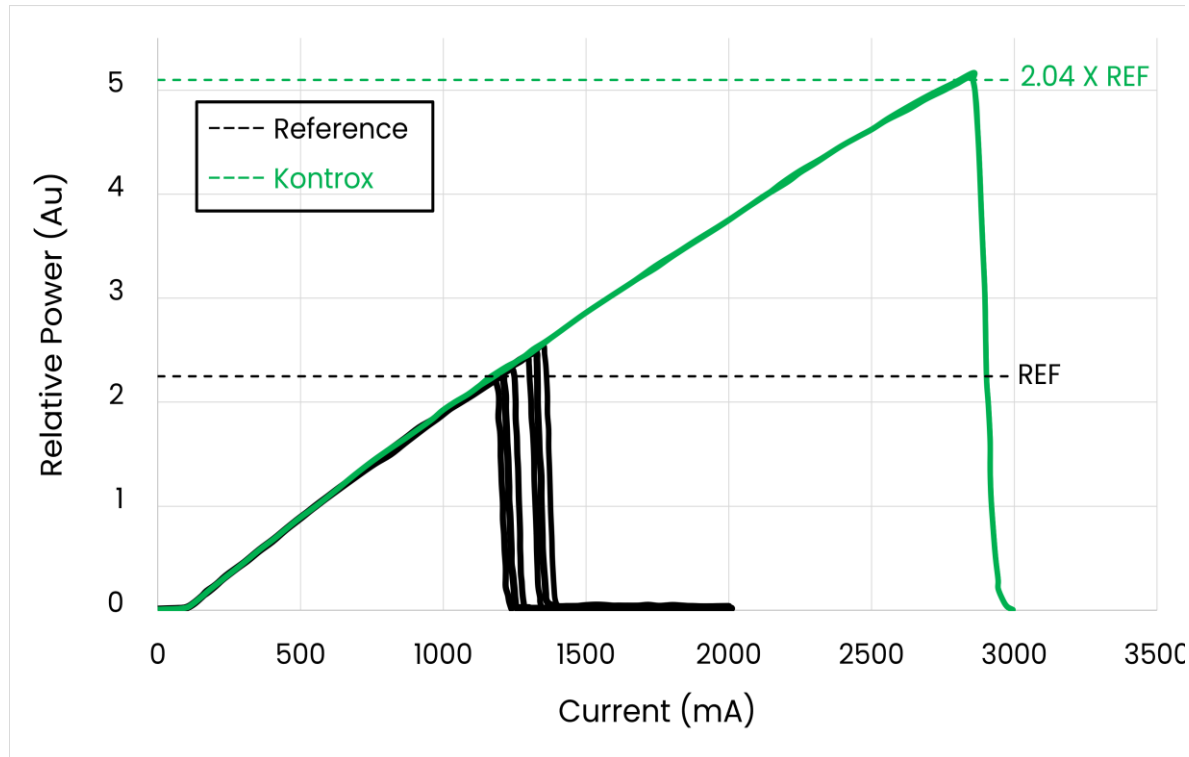

CUSTOMER LD Lifetime & Reliability Results

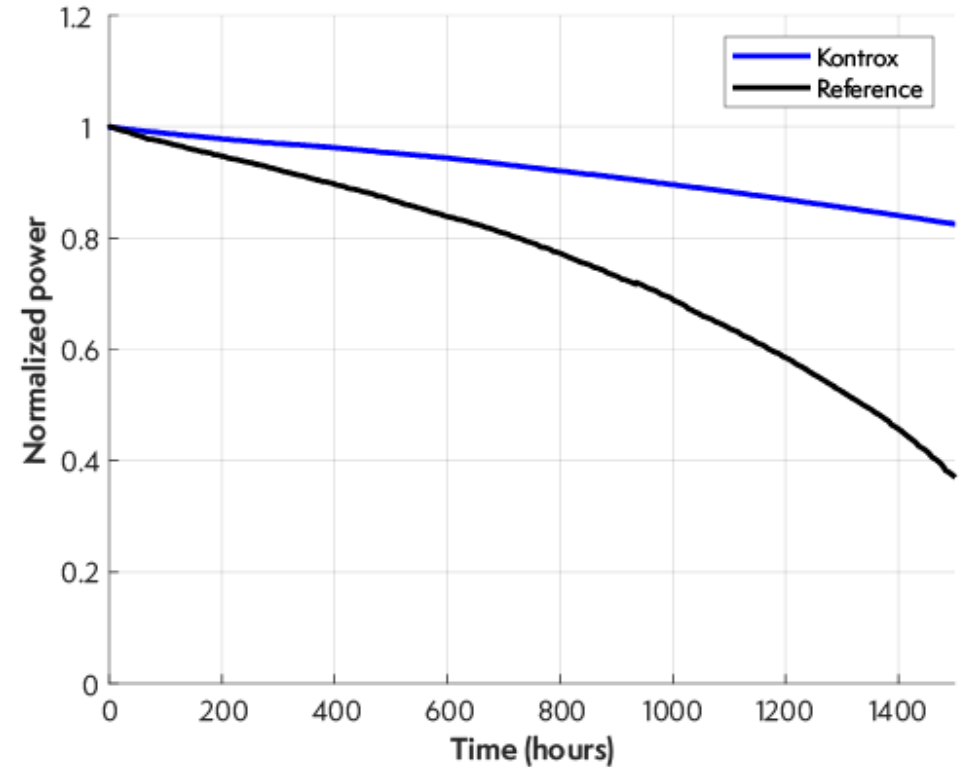

# Kontrox™ Photonics : Performance ( $\mu$ LEDs)

Enables higher efficiency & lower power consumption

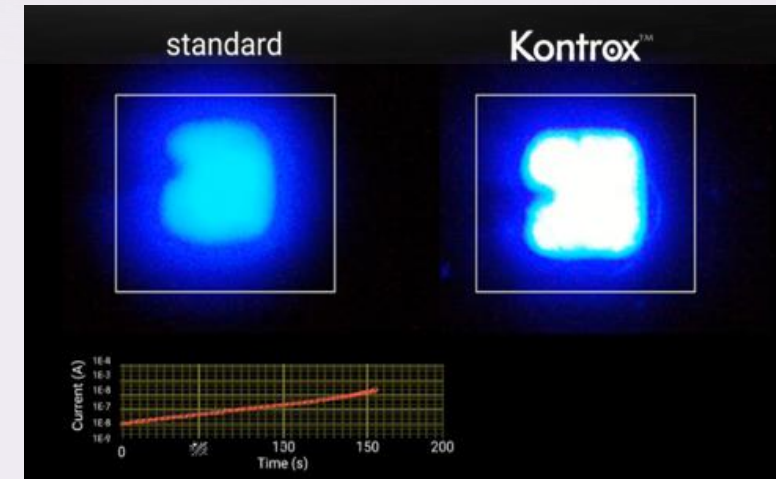
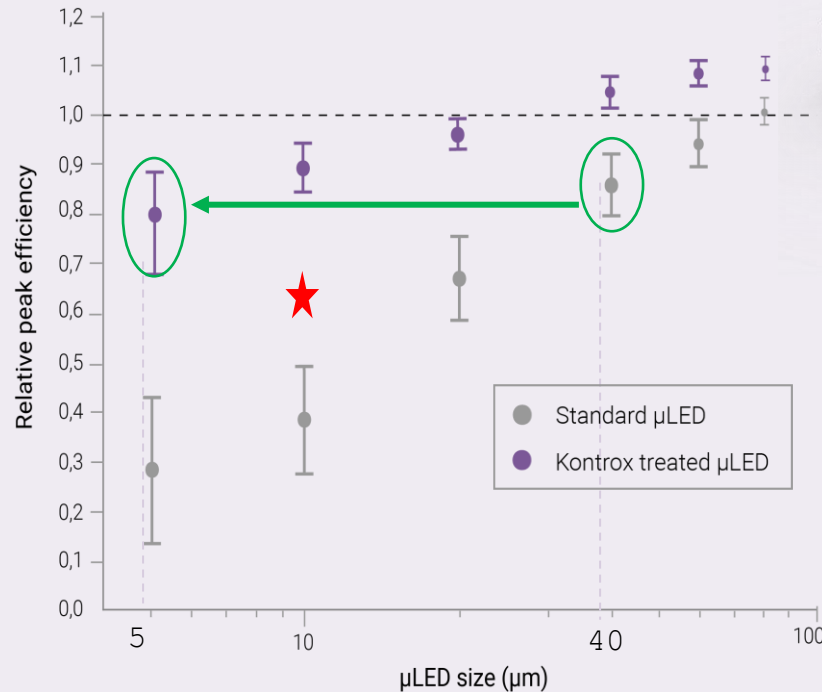
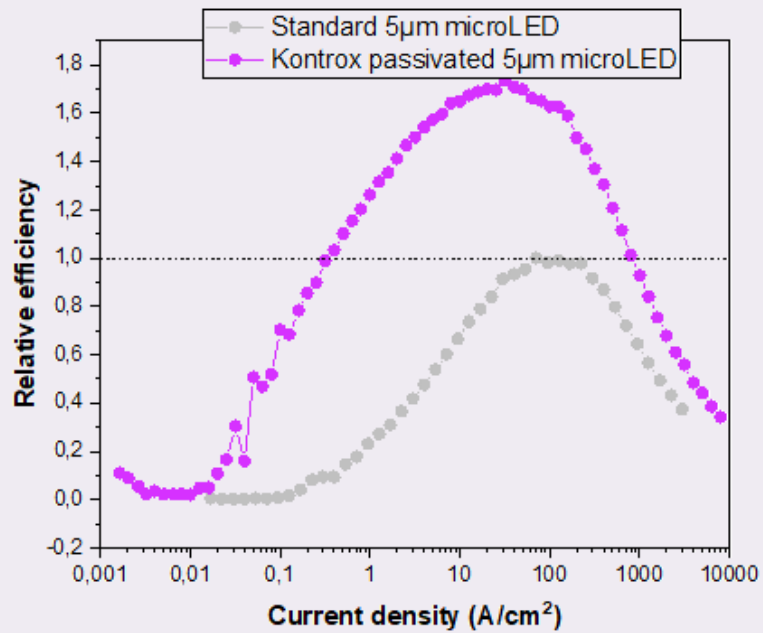
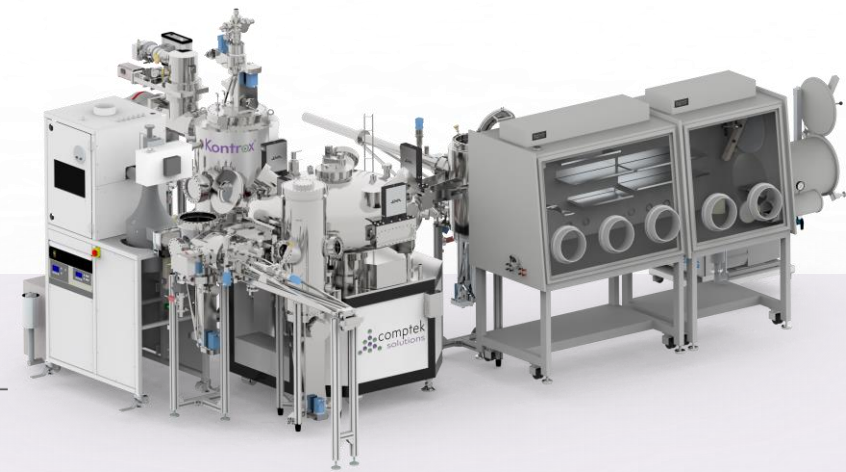

## Important chip size reduction opportunity

- 5µm chip can perform as good as a 40µm.
- **10 times more microLED chips/wafer**



**Reduction of production volumes / Costs**



**Less natural resources & electricity**



**Less waste**

# Kontrox™ 200mm Wafer Pilot Line

## R&D System Overview

## μled & Power/RF Electronics

### Main components:

1. Kontrox Reactor
2. Radial Distribution Chamber
3. ALD Load Lock
4. Glove Box Load Lock
5. Storage Chamber
6. Glove Box
7. ALD

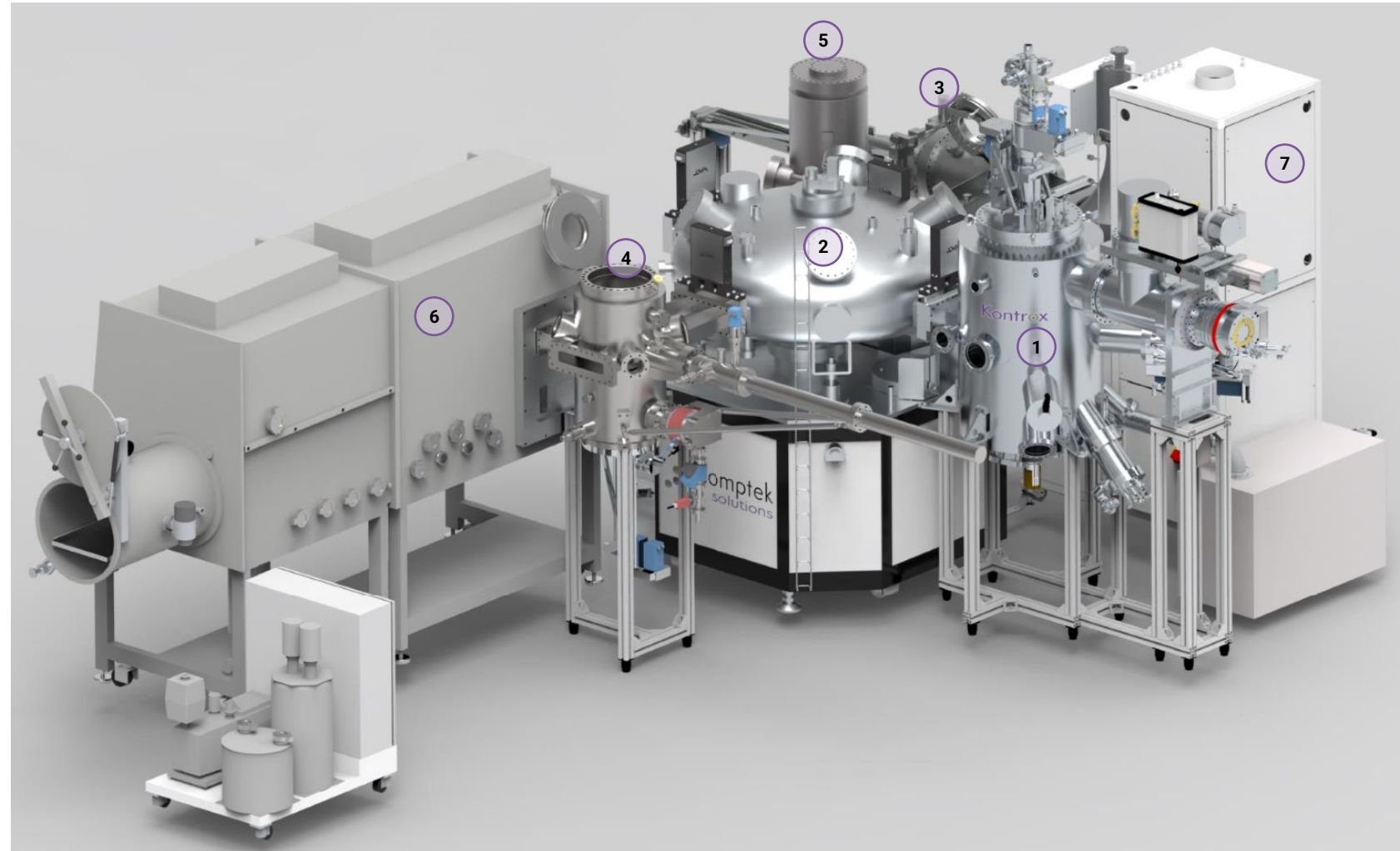



# Kontrox™ 200mm Wafer Pilot Line



## Features

- Fully automated system
- Integrated Kontrox + ALD
- Support up to 200mm wafers
- Sample loading from clean room
- ALD process integrated
- Storage up to 10pcs wafers
- Base pressure  $5 \times 10^{-10}$  mbar
- Process pressure up to  $5 \times 10^{-4}$  mbar
- Process temperature: up to 850C
- Custom holder designs for different sample sizes

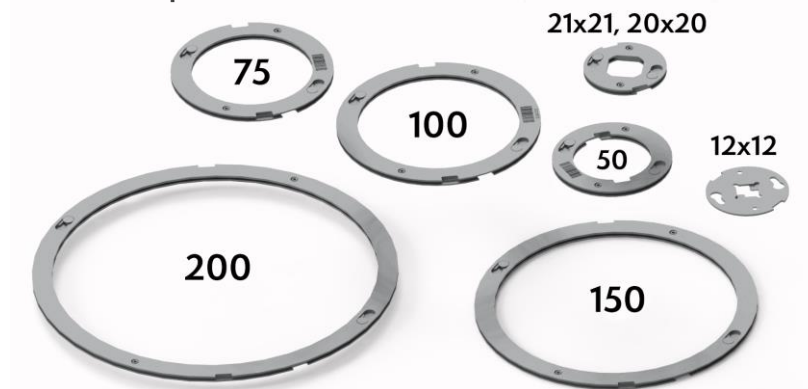

# Major Activities and Projects

## 200mm Wafer Blue $\mu$ led

Outstanding First-Test Results with Kontrox™

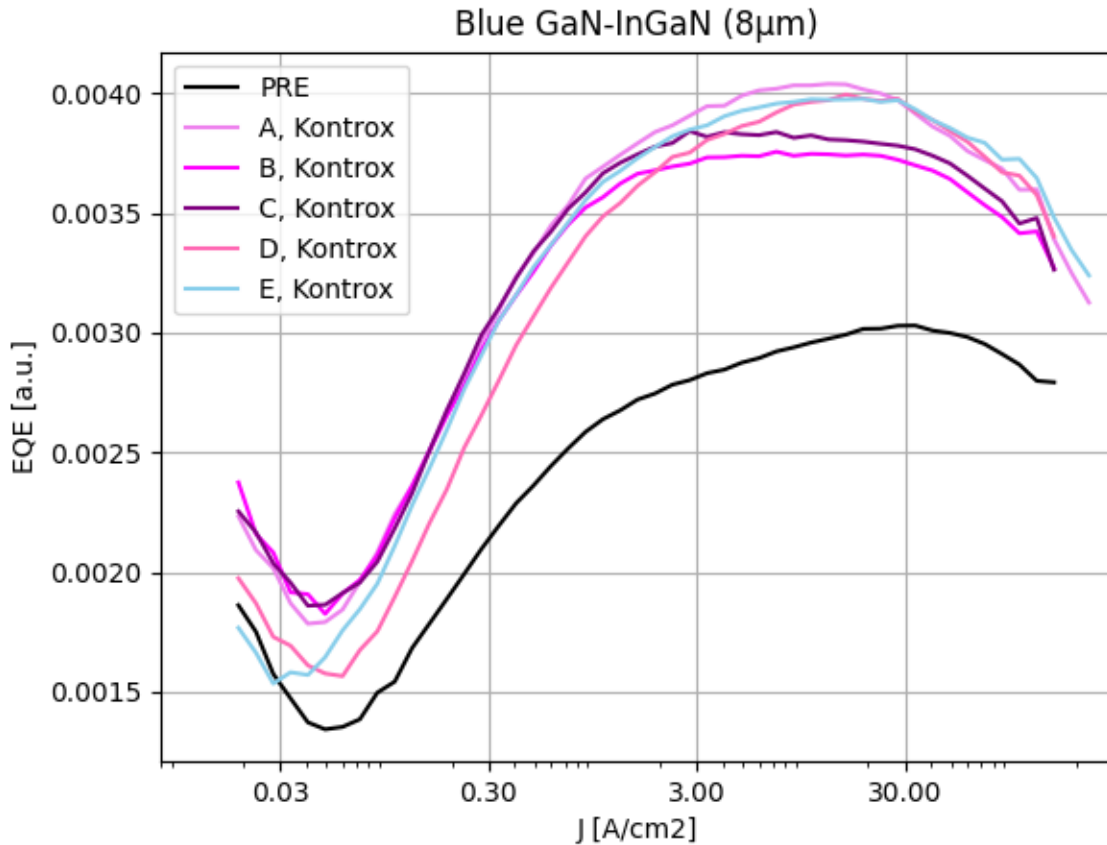

## New 200mm R&D Tool & other $\leq 100$ mm

- III-V substrate passivation for IR new EDF project
- Lasers and Substrates
- 150/200mm wafer Blue, Red & Green  $\mu$ led
- Quantum IC material
- Power Transistors & RF transistors

## LASE16 Mass Production Tool

- GaAs, InP and GaSb customized recipes for MP of EEL
- GaN EEL Kontrox passivation development

## Photonics Wafer & Laser

## Characterization system SMART FAB

$\mu$ PL mapping, nanoPL, TRPL, Microprobes, IV, CV, EL, Optical inspection, reflectivity, Wafer bow & much more

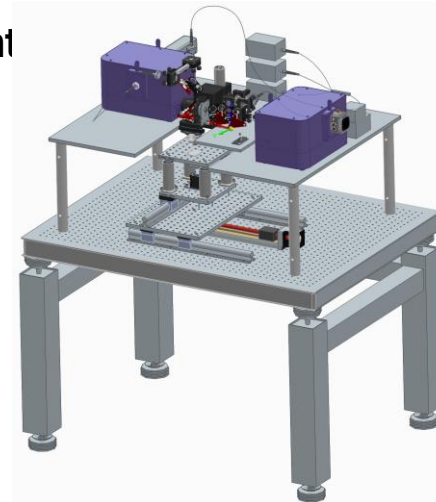

# Our Business Model

## Collaboration Model Overview



1

### Customized process

Process optimization for customer-specific device/materials

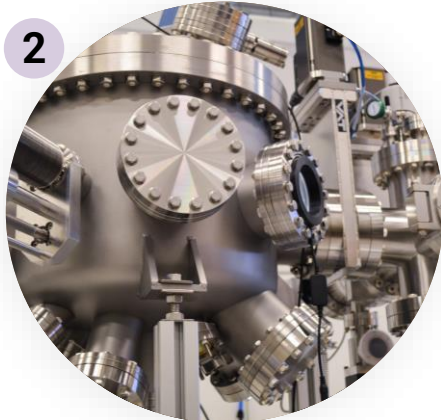

2

### Equipment mass production

**EEL** : Comptek own passivation system LASE16  
**WAFERS** : Own R&D Tool + Partnerships with world-leading semicon equipment manufacturers

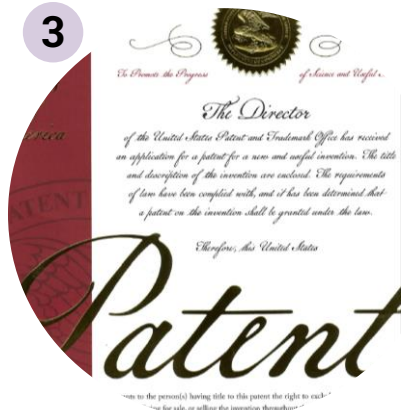

3

### Freedom to operate

via license to Comptek's IP portfolio

## Collaboration Model



Proof of concept

Technology optimization under Dev Agreement

Tech transfer

Commercial implementation License agreement

# Thank You



**In search of improved performance?**

Comptek Solutions is your partner



**For more information**

Please contact us at  
[contact@comptek-solutions.com](mailto:contact@comptek-solutions.com)

Elias Tsiatas  
Director Sales & BD  
[elias@comptek-solutions.com](mailto:elias@comptek-solutions.com)  
+358405035300