

UV-Nanoimprinting of Micro Optics on Foil

Paul Hartmann

**JOANNEUM RESEARCH
MATERIALS**

Institute for Sensors, Photonics and Manufacturing Technologies

Salzburg, September 18th, 2024

www.joanneum.at/materials

Roll-2-Roll UV-NIL Pilot Line

Nano goes Macro !

2

MATERIAL



e.g. Poly-
Urethane-
Acrylates

SIMULATION & DESIGN

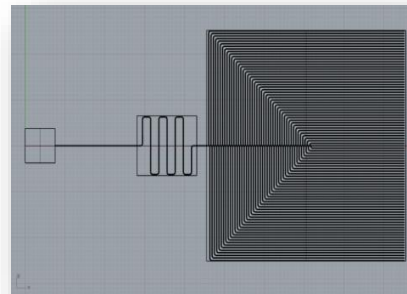

e.g. COMSOL,
Ray Tracing

MASTER

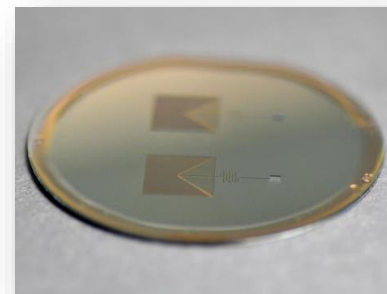

e.g. Maskless
Laser Lithography

STAMP / SHIM



Step & Repeat UV-NIL

PRODUCTION



R2R-UV-NIL

MICRO-OPTICS IS...

Phabulous

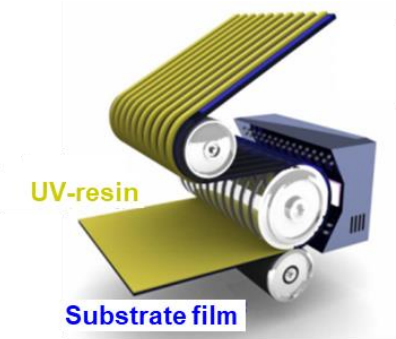
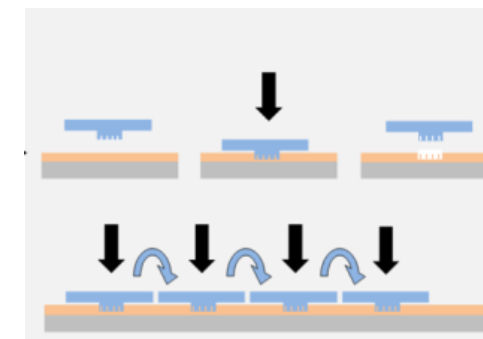
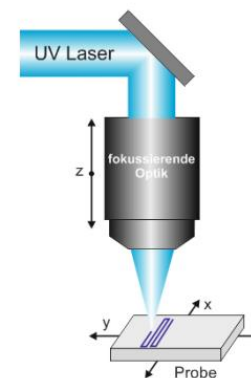

UPSCALING 

Imprinting is powerful

3

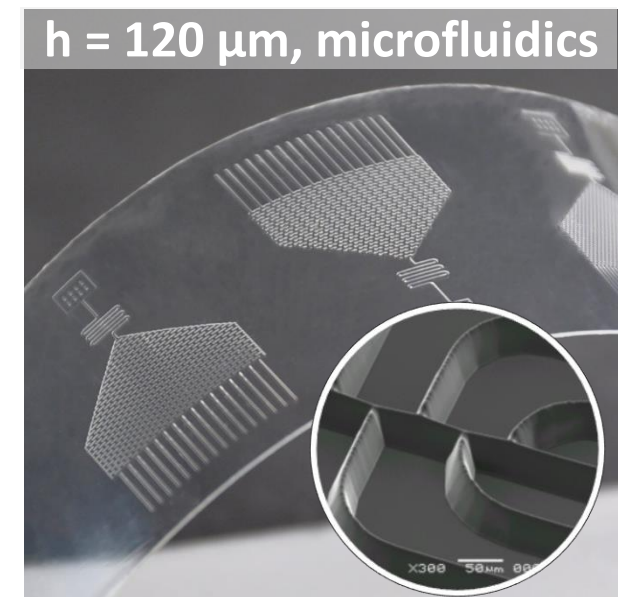
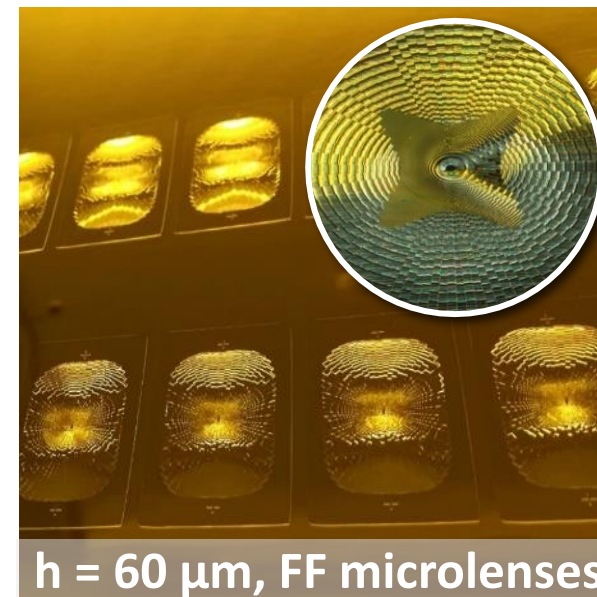
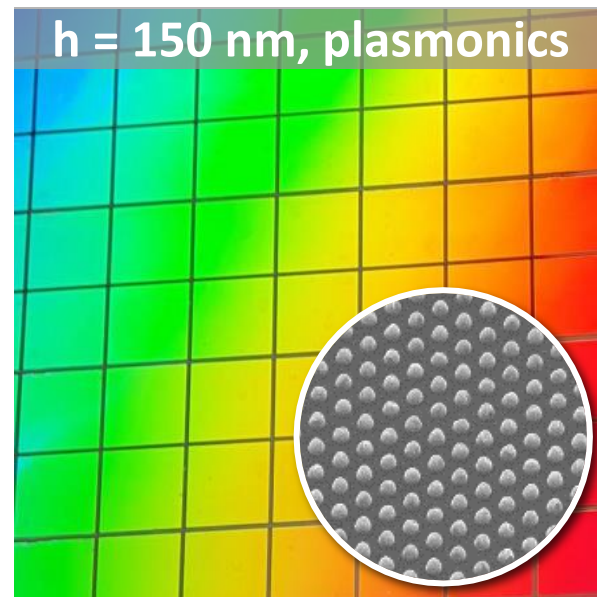
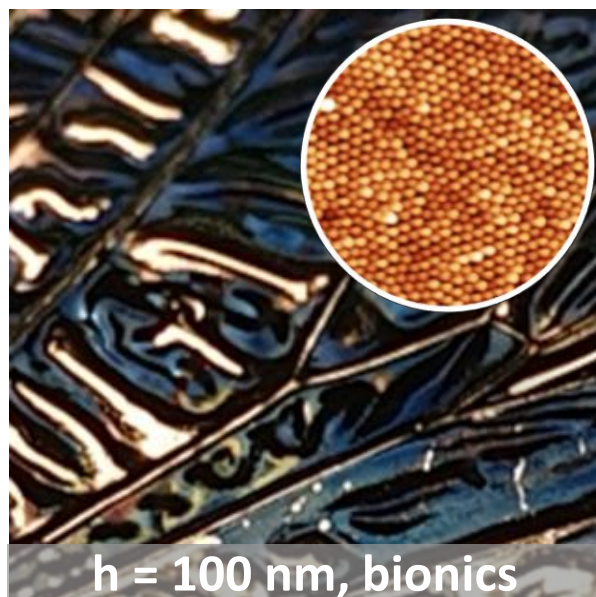
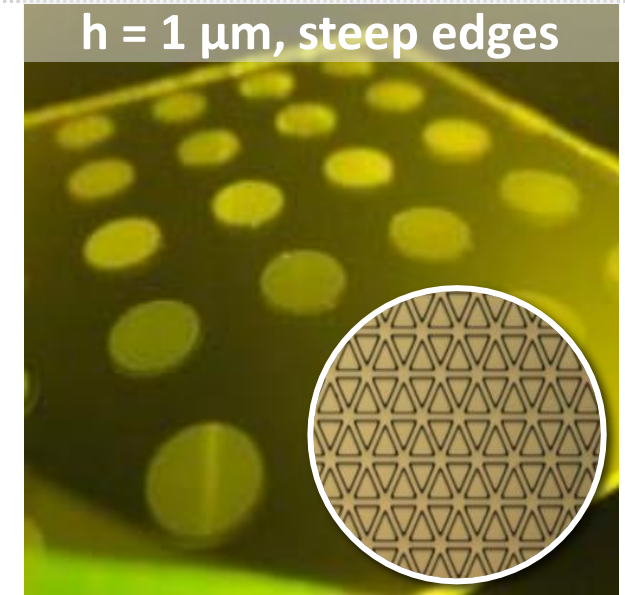
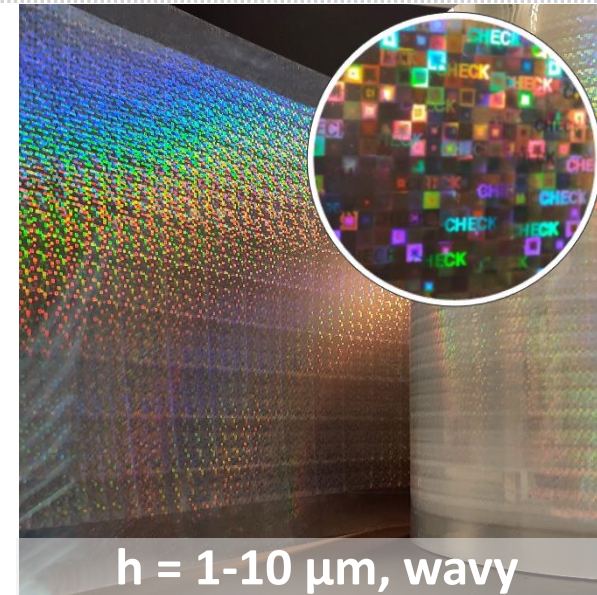
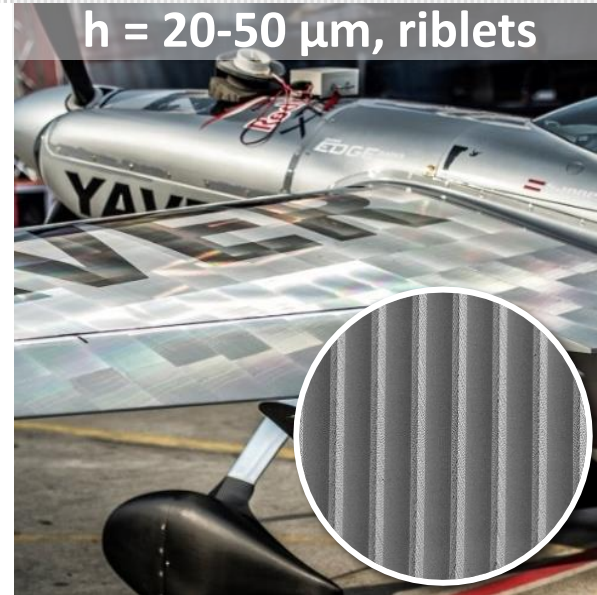
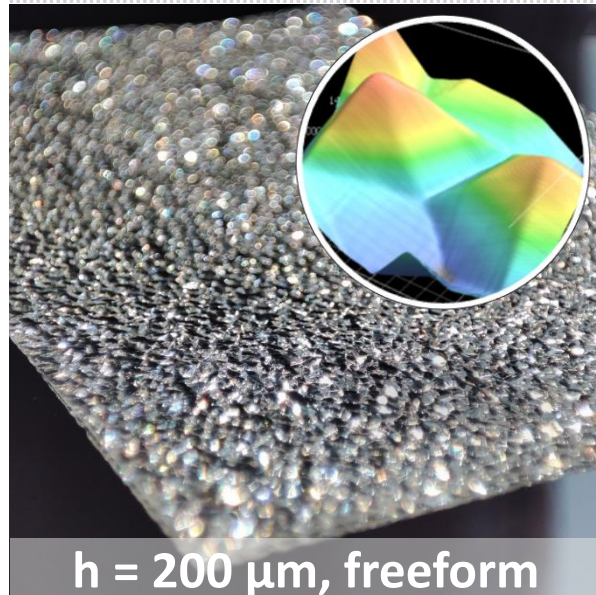



4

Use Case 1: Multi-Color Spot-Light

Application:

Freeform micro-optics to realize a homogeneous luminance and light distribution from a multi-color spot-light

Upscaling target: Seamless Step & Repeat Upscaling for Roll-to-Plate

Seamless stitching of a hexagonal small-scale master to create a large-area continuously patterned tool – 200x200 mm²

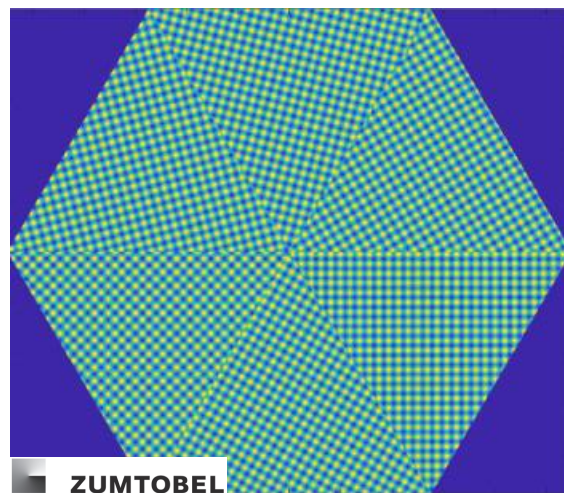

Design of FFMO structure
h = 70 μm

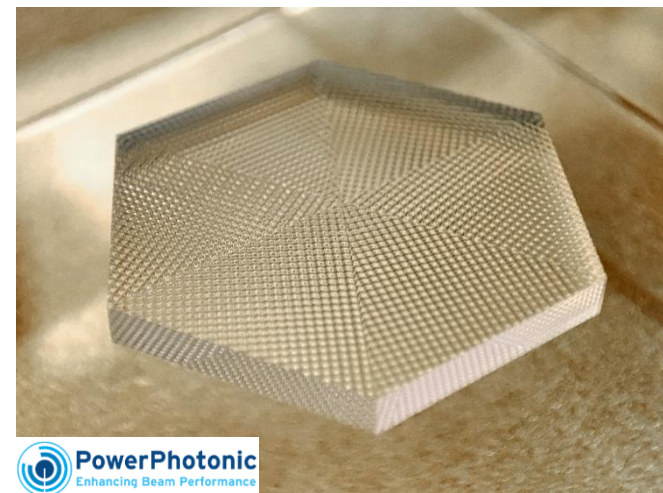

d ~ 20 mm quartz master
(laser ablation)

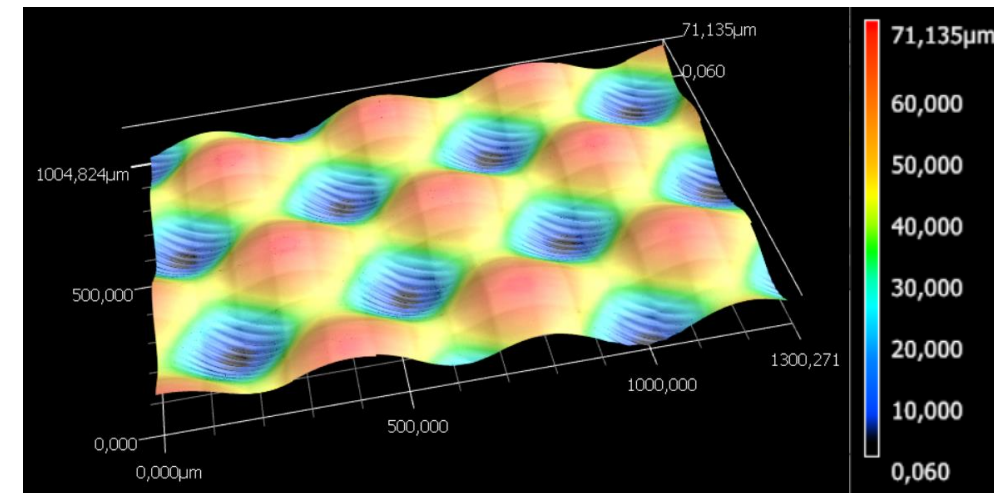

3D pattern

Seamless Step & Repeat Upscaling

5

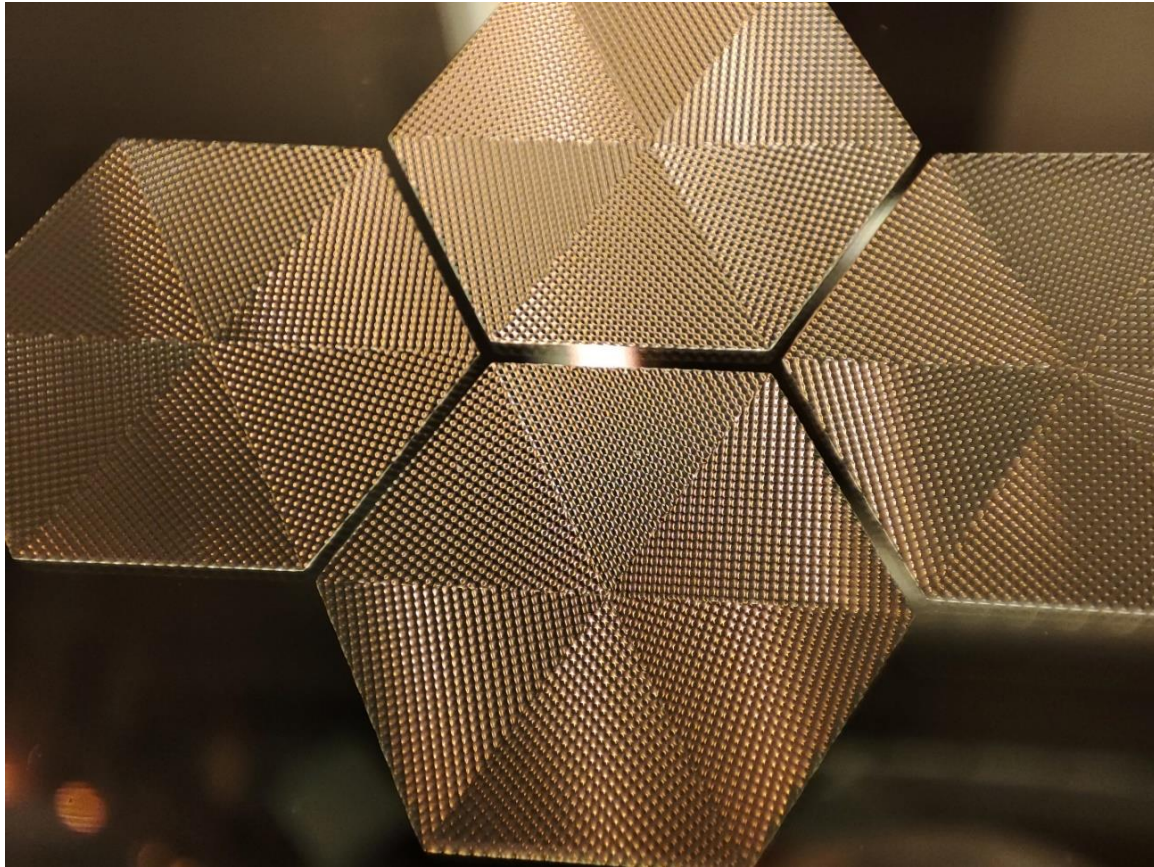

Step&Repeat UV imprints on PET foil
distance = 1 mm

6

Seamless Step & Repeat Upscaling

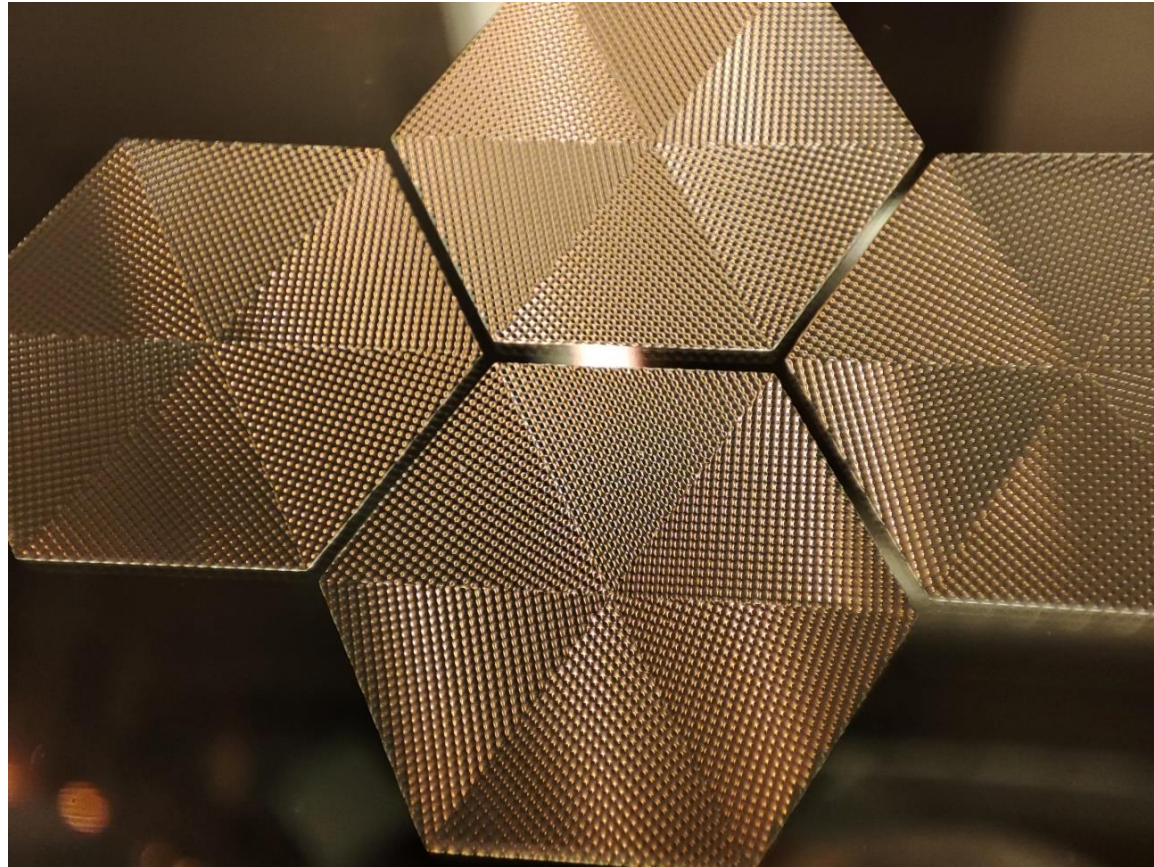

Step&Repeat UV imprints on PET foil
distance = 1 mm

Distance and
rotation optimization

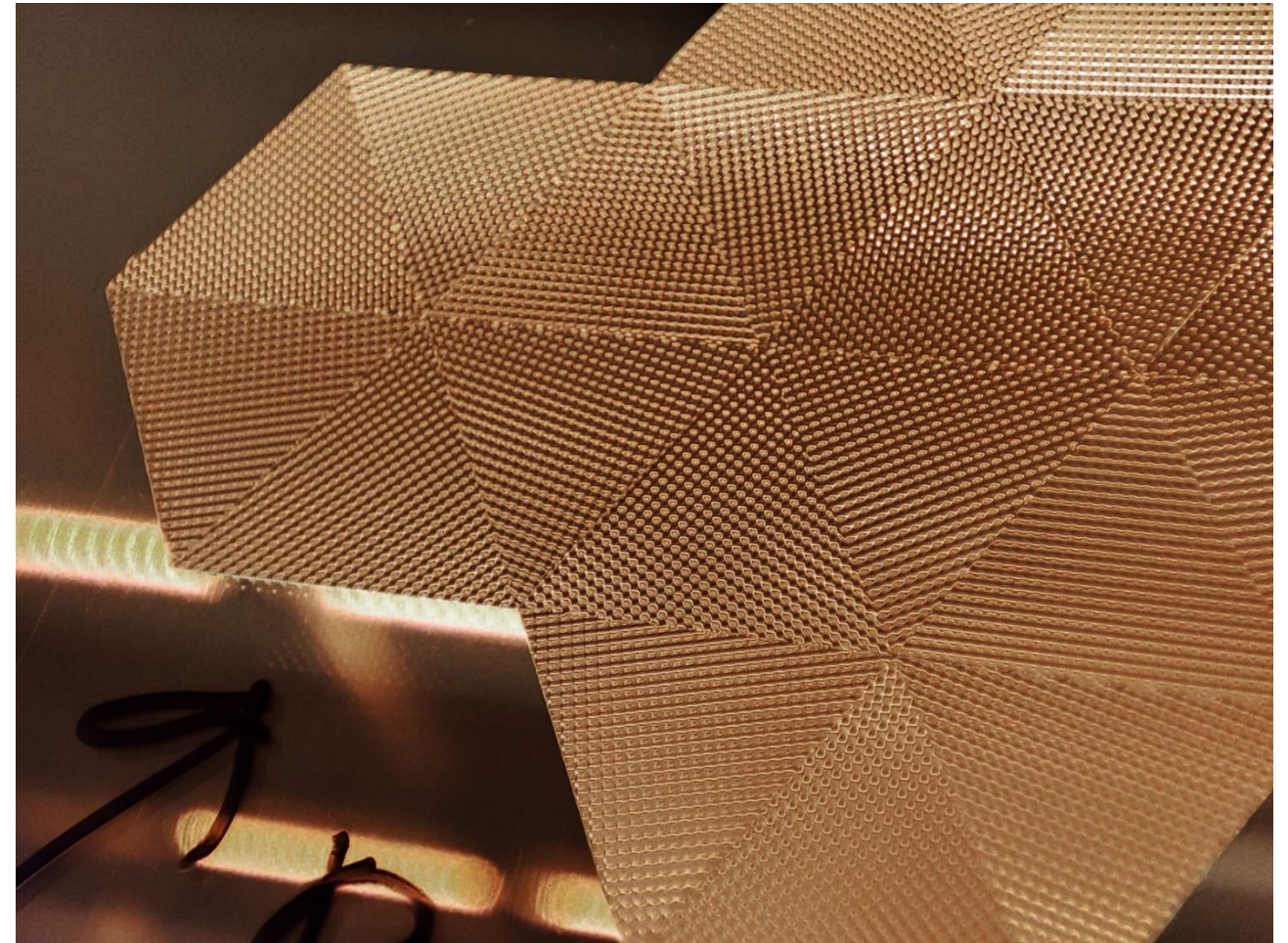



Roll-to-plate (R2P) replication

7

Converting the poly-shim to a durable Ni tool

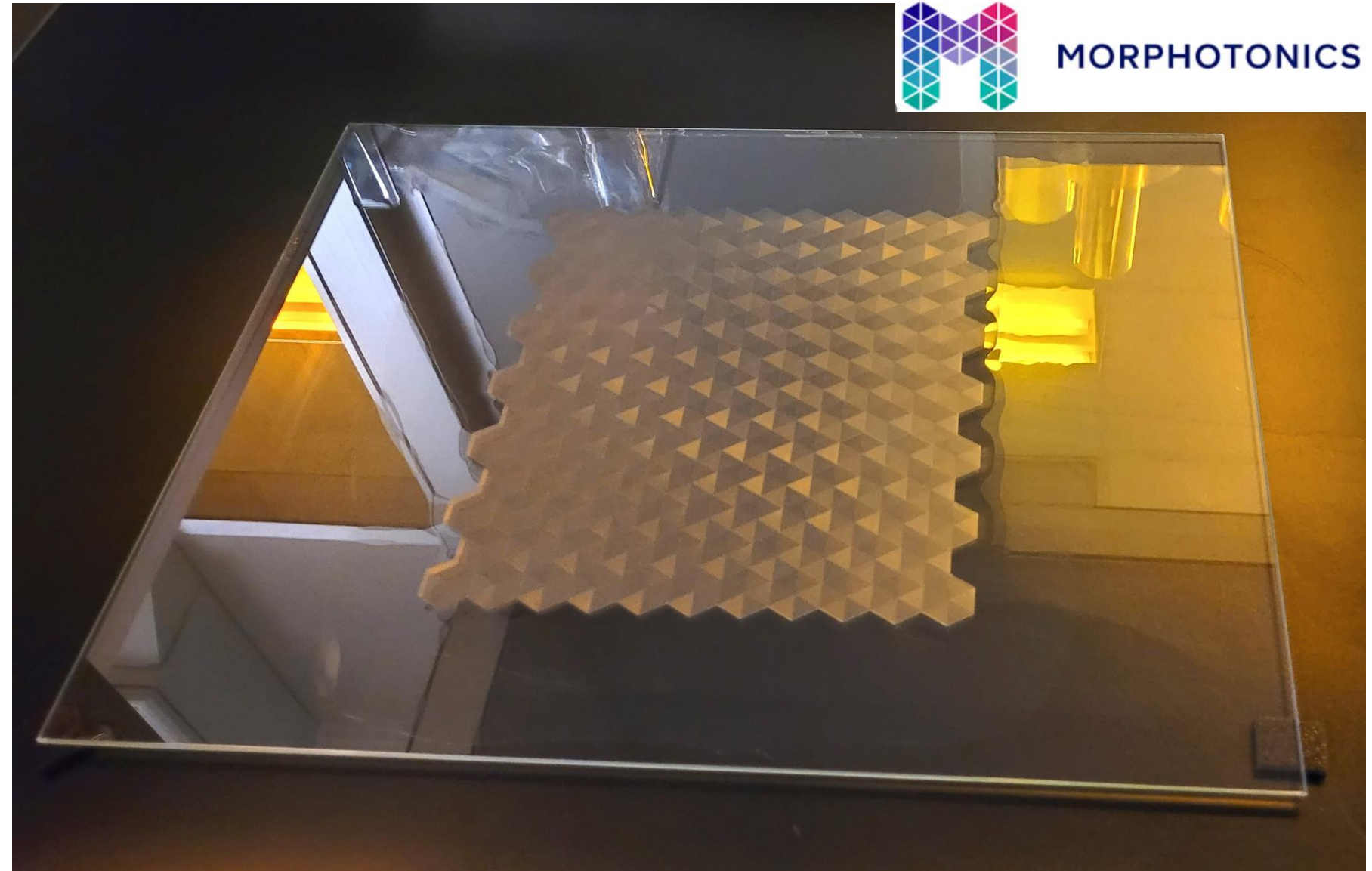
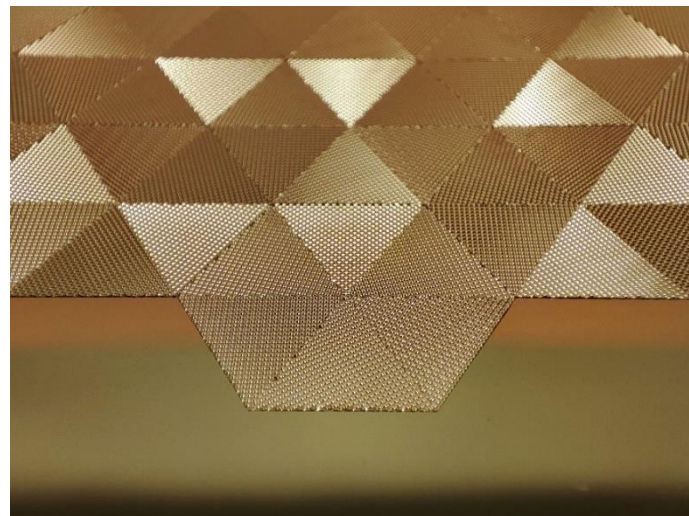
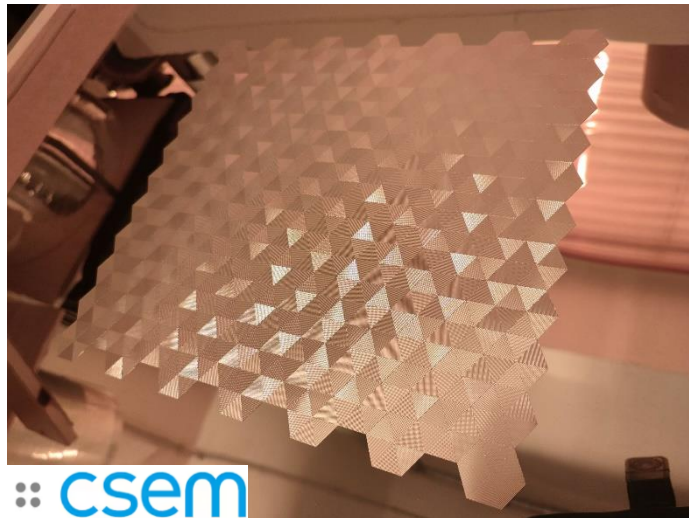

Use Case 2: Decorative Films

Application:

Freeform micro-facets to realize a sparkling effect for luxury goods

Upscaling target: Seamless Step & Repeat Upscaling for Roll-to-Roll production

Seamless stitching of distributed facets with extremely high edge accuracy, low shrinking and low Abbe number



Resin with high dispersion

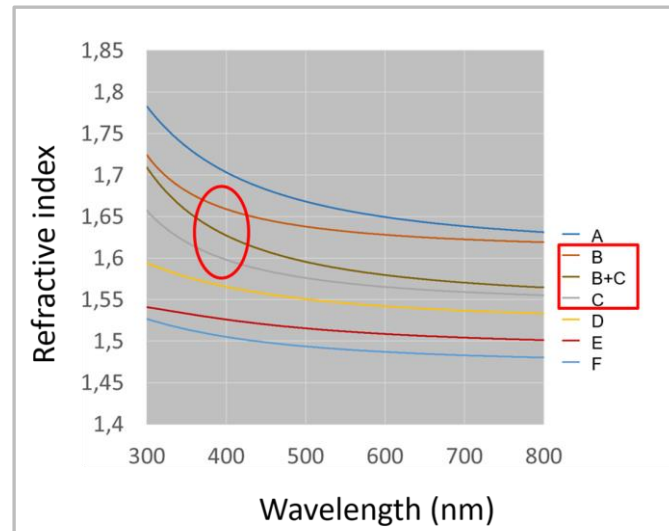

„Crystals“ with facet designs

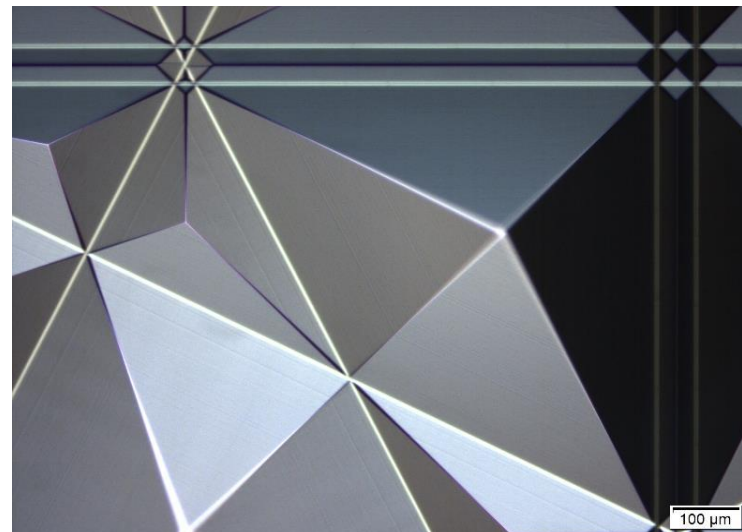

Double side imprinted „crystals“

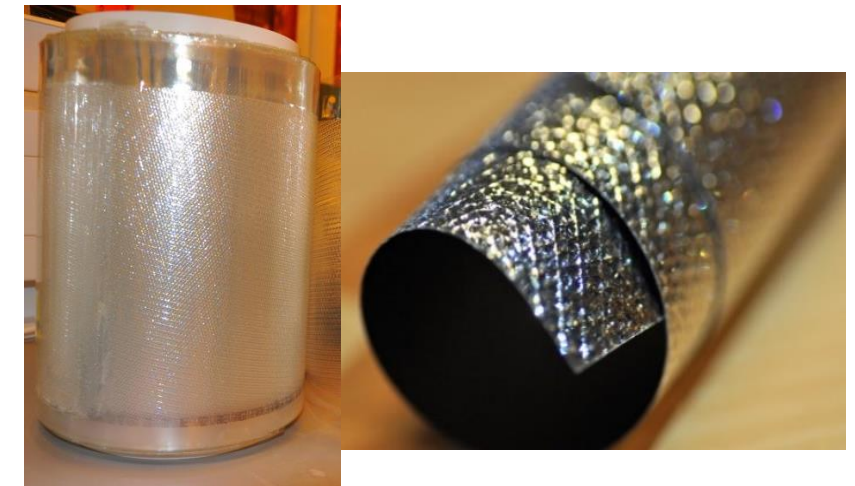

Roll-to-roll (R2R) replication of facets with high accuracy of replication

9

R2R UV imprint into high index, high dispersion resin

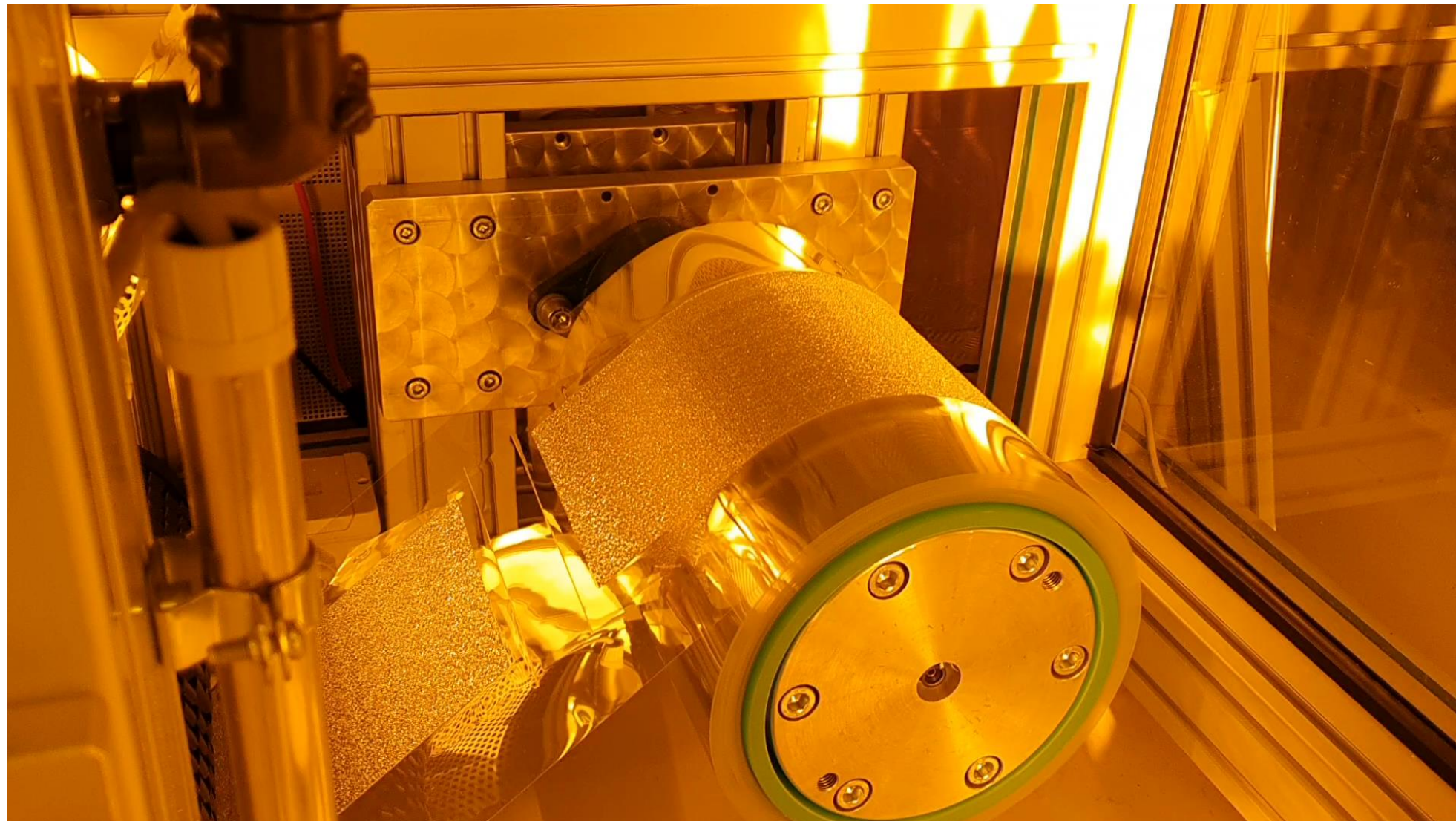

video

$v = 1 \text{ m/min}$

Roll-to-roll (R2R) replication: finished products



R2R UV imprint into **high dispersion resin**
+ R2R backside metallized  Fraunhofer
View: reflection

video



R2R UV imprint into **high dispersion resin**
View: transmission



Use Case 3: Interior Lighting for Trains

Application:

Freeform micro-lenses for a homogeneous large-area direct-lit luminaire as a linear lens array

Upscaling target: Grey Scale Lithography Mastering, Step & Repeat and Roll-to-Plate production

Freeform lenses with highest surface quality and shape fidelity



S&R working stamp

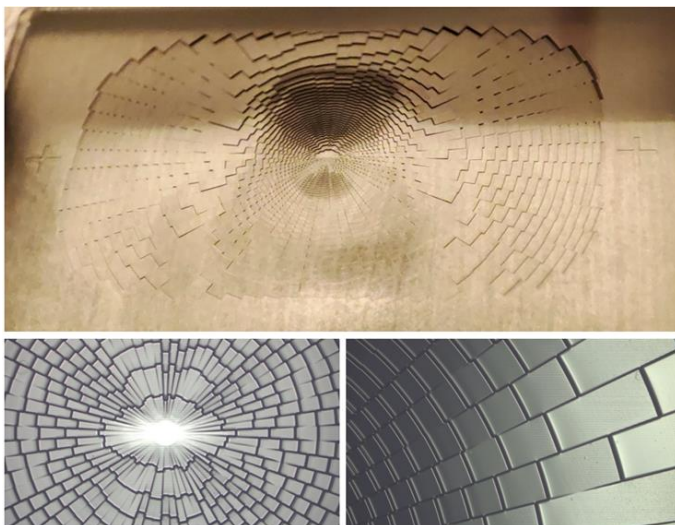

Polymer shim



Roll-to-Plate lens arrays

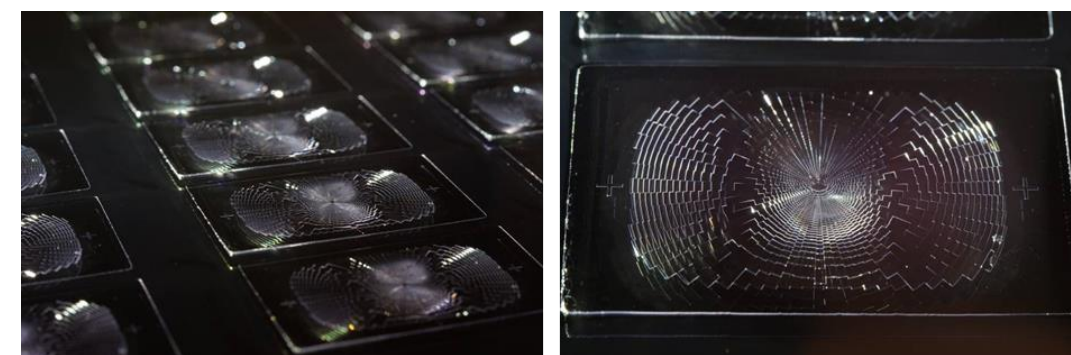

Mastering: Grey Scale Lithography

Main features

- ◆ Structuring on planar and curved substrates
- ◆ Min. feature size(XY): 200 nm
- ◆ Max. structure height(Z): 60 μm
- ◆ Aspect ratio: 4:1
- ◆ Structure type: 1D, 2D, 2.5D and free-form
- ◆ Writing speed (CD = 1 μm) 1 cm^2/h

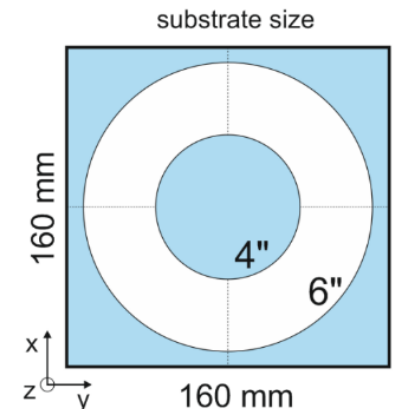
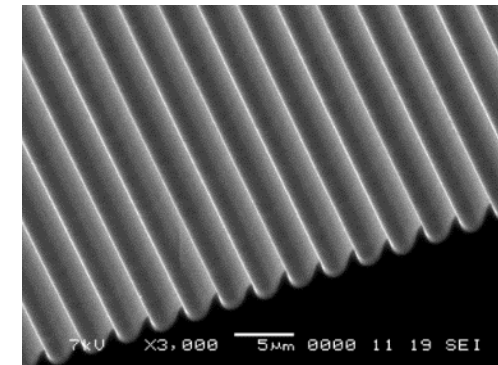
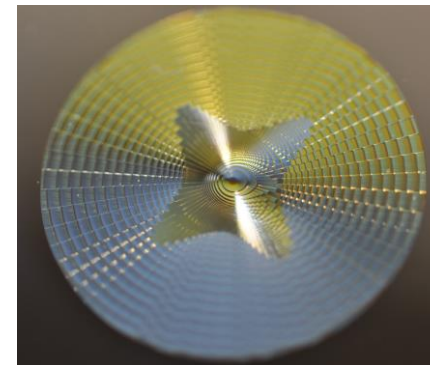
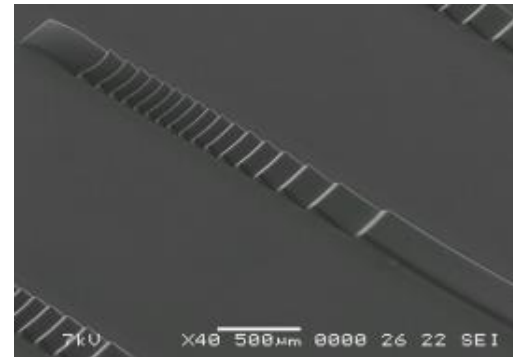
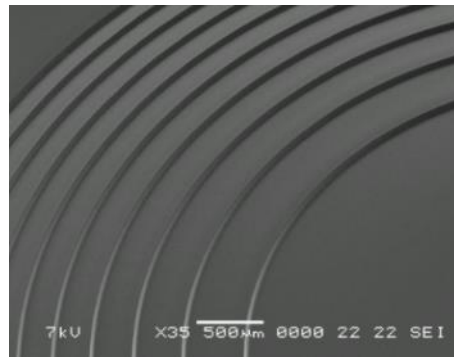
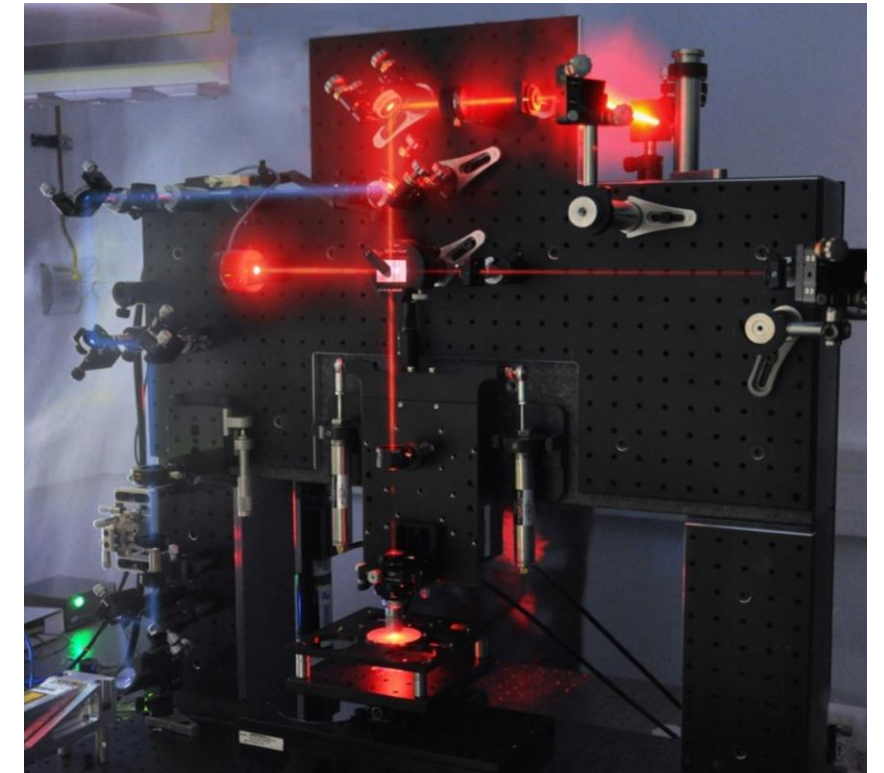

Using UV Imprint technologies

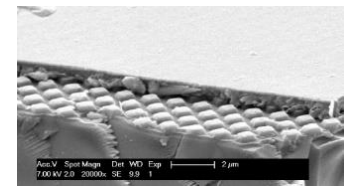
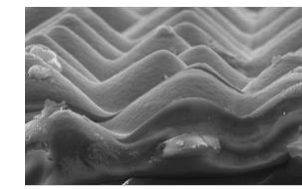
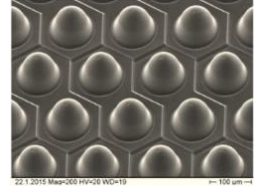
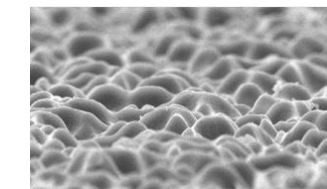
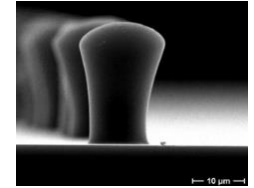
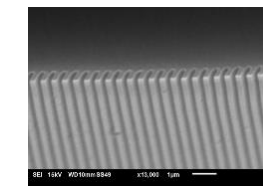
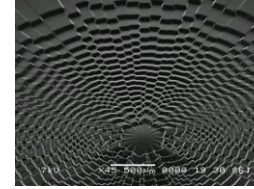
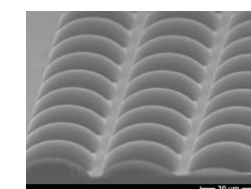
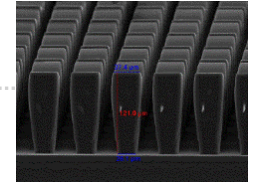
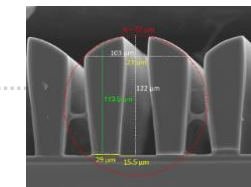
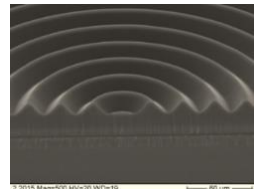
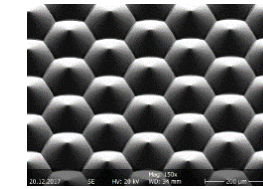
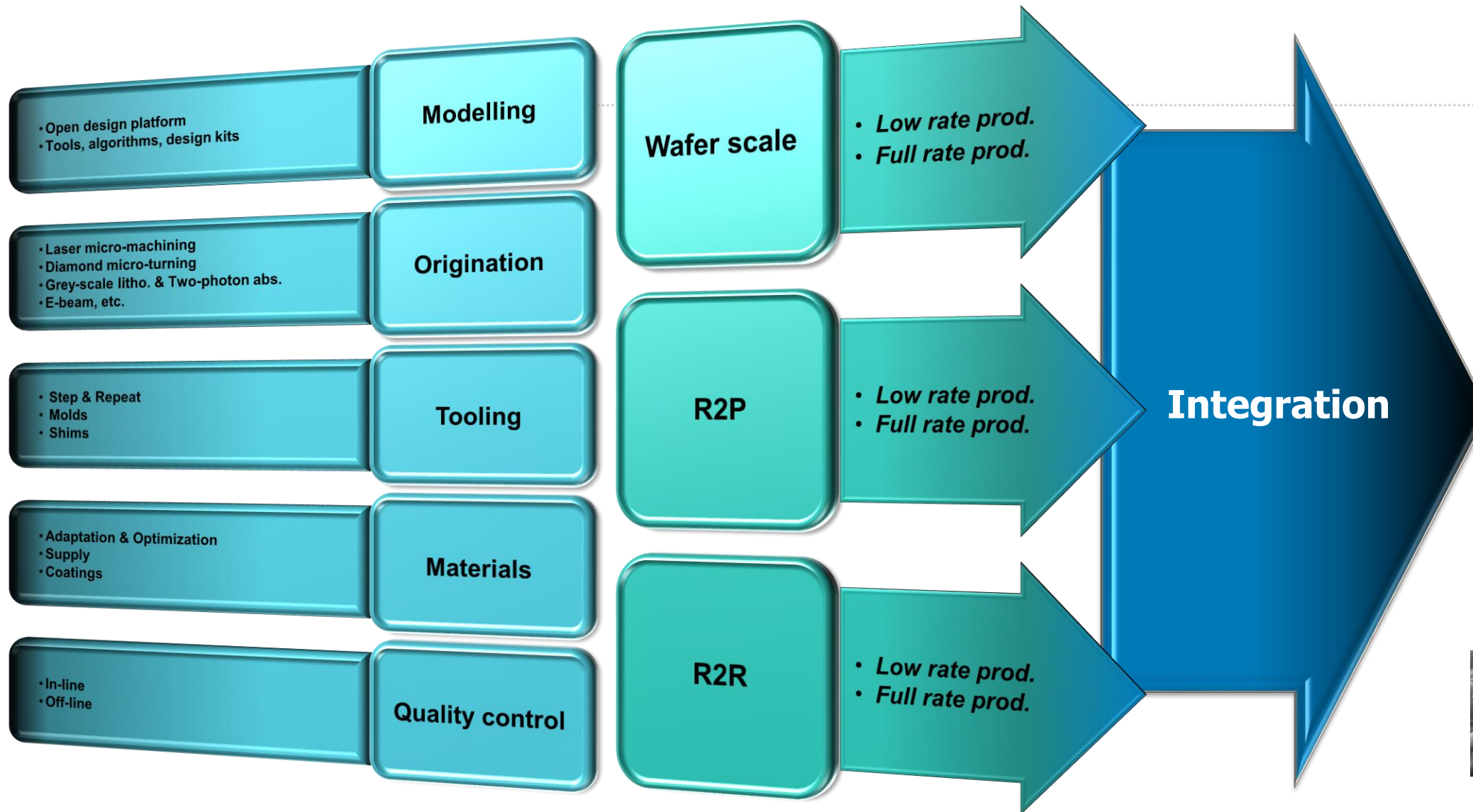

To support European Industry

MICROOLED

SEISENBACHER

SWAROVSKI

FORVIA
HELLA

ZUMTOBEL



Thank you for your attention!

JOANNEUM RESEARCH
Forschungsgesellschaft mbH

MATERIALS –
Institute for Sensors, Photonics and Manufacturing Technologies

Franz-Pichler-Straße 30
8160 Weiz, Austria

Tel. +43 316 876-3000
materials@joanneum.at

www.joanneum.at/materials

