



imec

On-chip Spectral Imaging
for Earth Observation

EPIC Photonics for Space event: opening new horizons

Paris 22/09/2023, Bavo Delauré – bavo.delaure@imec.be

IMEC (founded in 1984)







- World-leading R&D in nano-technology & high-tech applications
- **>5500** international R&D top talents, >90 nationalities
- Unique **€ 3B leading-edge semiconductor fabs**
- Delivering industry relevant technology solutions serving semiconductor, ICT, IoT, healthcare and energy markets
- **2022: € 800M revenues: 70% industry, 20% regional gov't, 10 % EU & regional programs**
- Collaborating with 600+ industrial partners
- Created **118 spin-off** companies and incubated **200+ start ups**
- **8 sites worldwide**

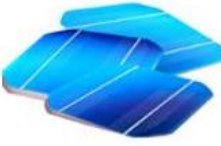

World-class infrastructure

- 1 200mm pilot line
- 2 300mm pilot line
- 3 Nano bio labs
- 4 NERF labs
- 5 Silicon solar cell line
- 6 Organic solar cell line

imec technology hub offering

<p>Core CMOS (7nm and below)</p> <p>Lithography Devices Interconnects</p> 	<p>CMORE</p> <p>Photonic, MEMS, 3D integration</p> 	<p>Organic electronics</p> 		
 <p>Energy</p> <p>Photovoltaic Power devices LEDs</p>	 <p>Life-Sciences</p> <p>Microfluidic Body Area Networks</p>	 <p>Wireless</p> <p>Low power RF & MMW</p>	 <p>Imaging</p> <p>Image sensors & Vision systems</p>	 <p>Sensor systems</p> <p>for industrial applications</p>

Exciting times

The background of the slide is a composite image. The lower portion shows a satellite view of Earth, focusing on the Middle East and surrounding regions, with the Mediterranean Sea and Persian Gulf visible. The upper portion shows a deep space scene with a bright star, a blue nebula, and a field of distant stars.

Ever increasing user expectations

- High spatial resolution
- High temporal resolution
- Digitized world
- Demonstrated EO added value
- Global observations

Technological advancements

- Performant small satellites
- Disruptive change in access to space
- Instrument miniaturization
- Industry driven

Today Earth Observation is everywhere

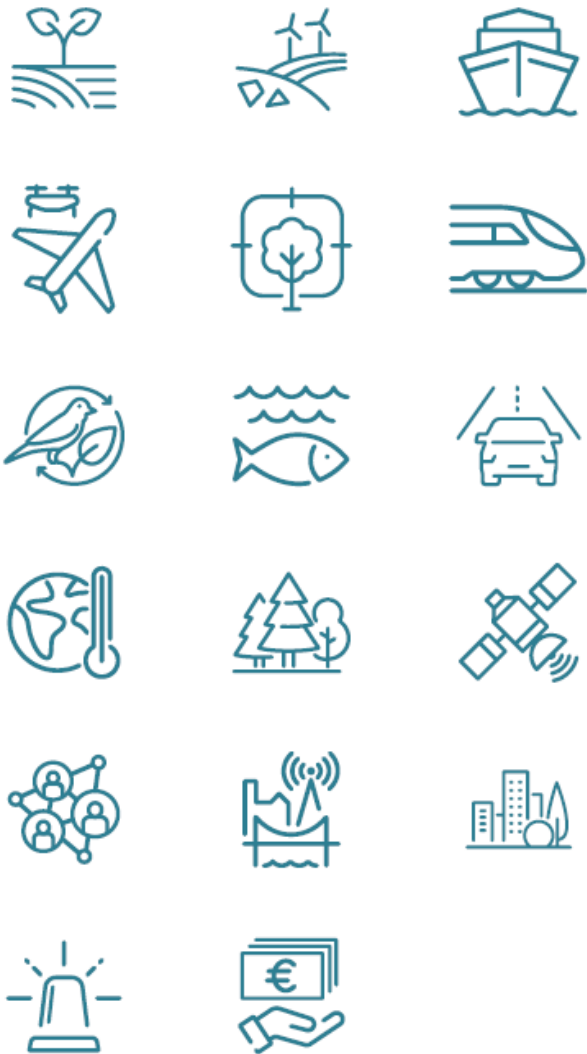

MARKET SEGMENTS

AGRICULTURE

AVIATION AND DRONES

BIODIVERSITY, ECOSYSTEMS AND NATURAL CAPITAL

CLIMATE SERVICES

CONSUMER SOLUTIONS, TOURISM AND HEALTH

EMERGENCY MANAGEMENT AND HUMANITARIAN AID

ENERGY AND RAW MATERIALS

ENVIRONMENTAL MONITORING

FISHERIES AND AQUACULTURE

FORESTRY

INFRASTRUCTURE

INSURANCE AND FINANCE

MARITIME AND INLAND WATERWAYS

RAIL

ROAD AND AUTOMOTIVE

URBAN DEVELOPMENT AND CULTURAL HERITAGE

SPACE

Small satellite constellations are taking over

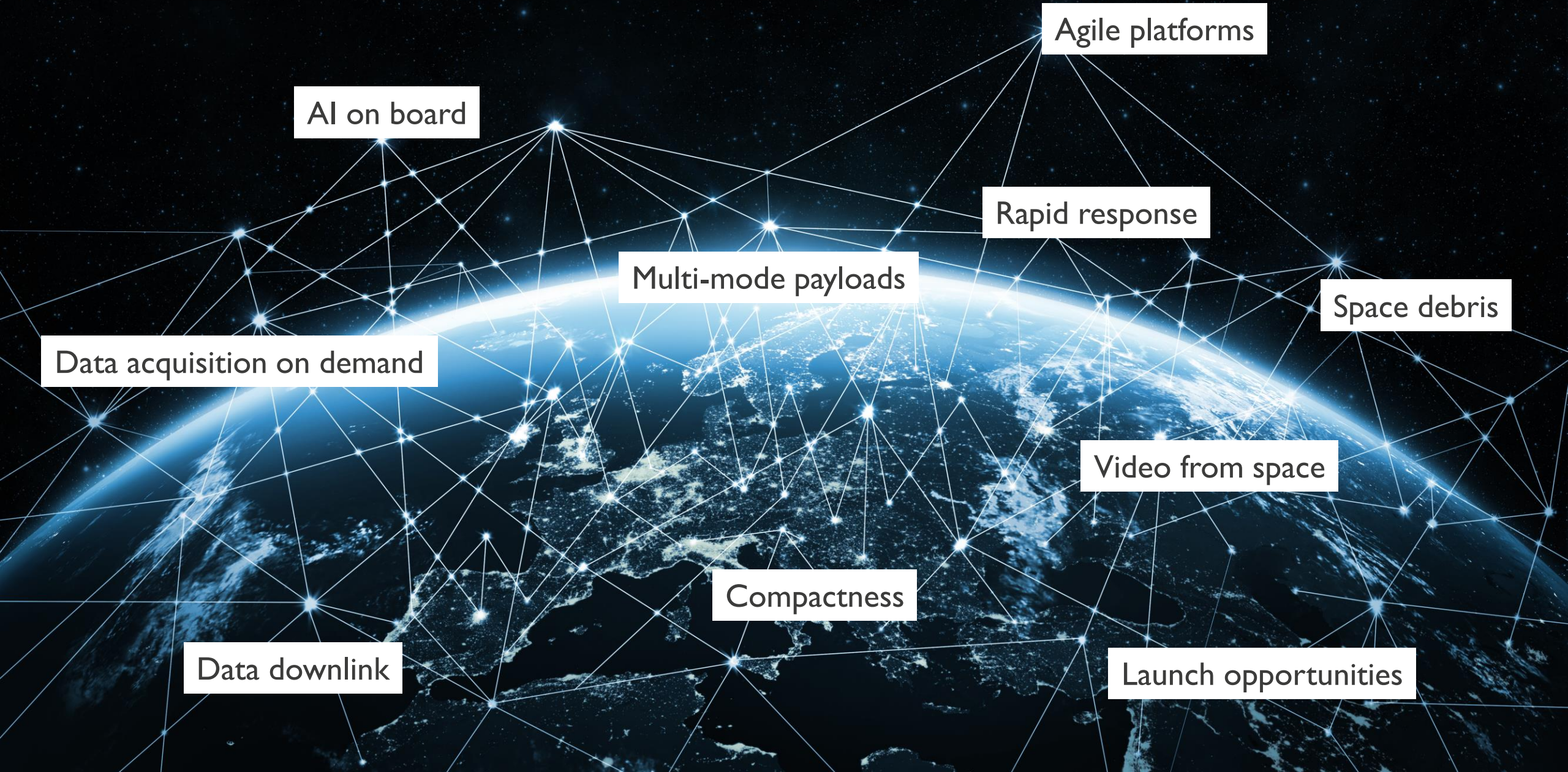

Spectral imaging opening a new dimension

POINT SPECTROSCOPY

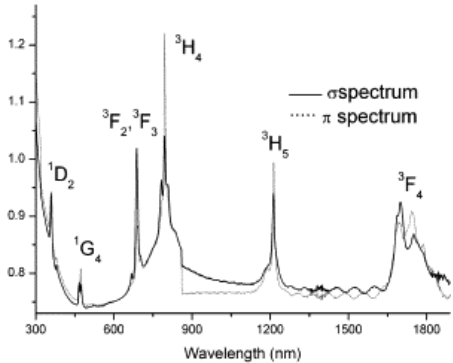
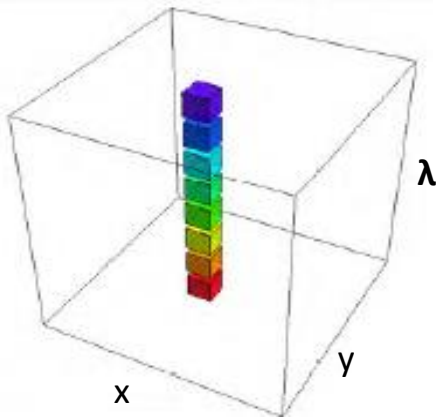

→ Accurate spectral analysis of one spatial pixel only

COLOR IMAGING

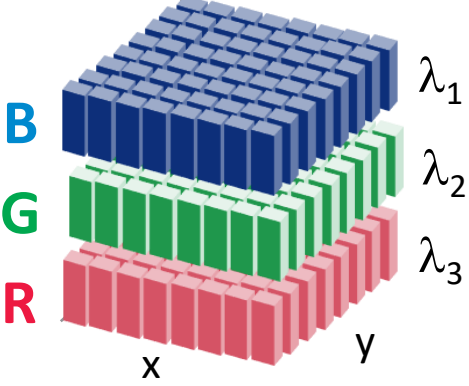

→ Seeing RGB colors of one image only

HYPERSPECTRAL IMAGING

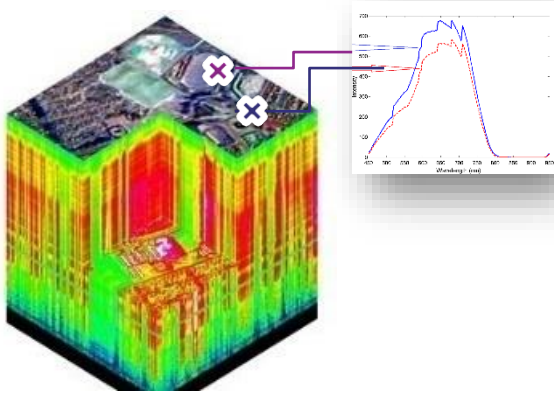
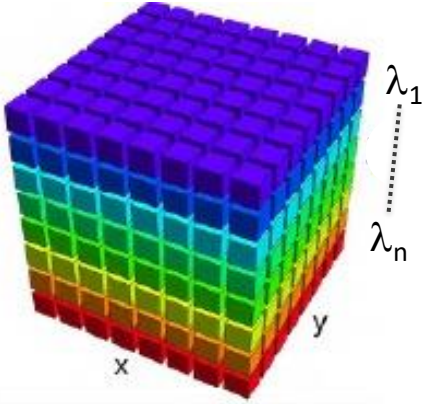

→ spectral signature images revealing objects chemical composition

CMOS made filters on image sensor wafers for spectral imaging

Accurate, mass manufacturable and extremely compact

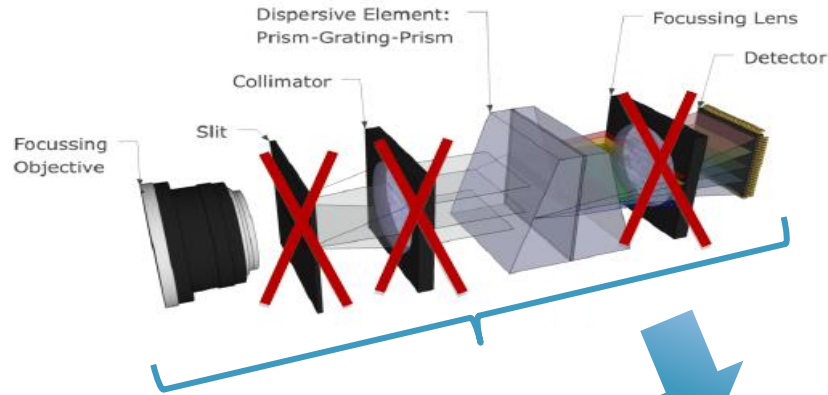

On-chip spectral filters

- Accurately patterned
- FSI and BSI compatible
- Scalable CMOS process
- Extremely clean
- Snapshot, video & line scanning
- Miniaturized and robust
- Easy to integrate @ system level
- VIS, NIR, SWIR and beyond

imec integrated approach

On-chip spectral imaging

Leveraging imec's class I cleanroom

- Wafer level processing
- Thin film filter deposition
- Lithographic patterning
- Dry and wet etching

World unique optical filters on chip:
scalable, precise, robust and extremely clean

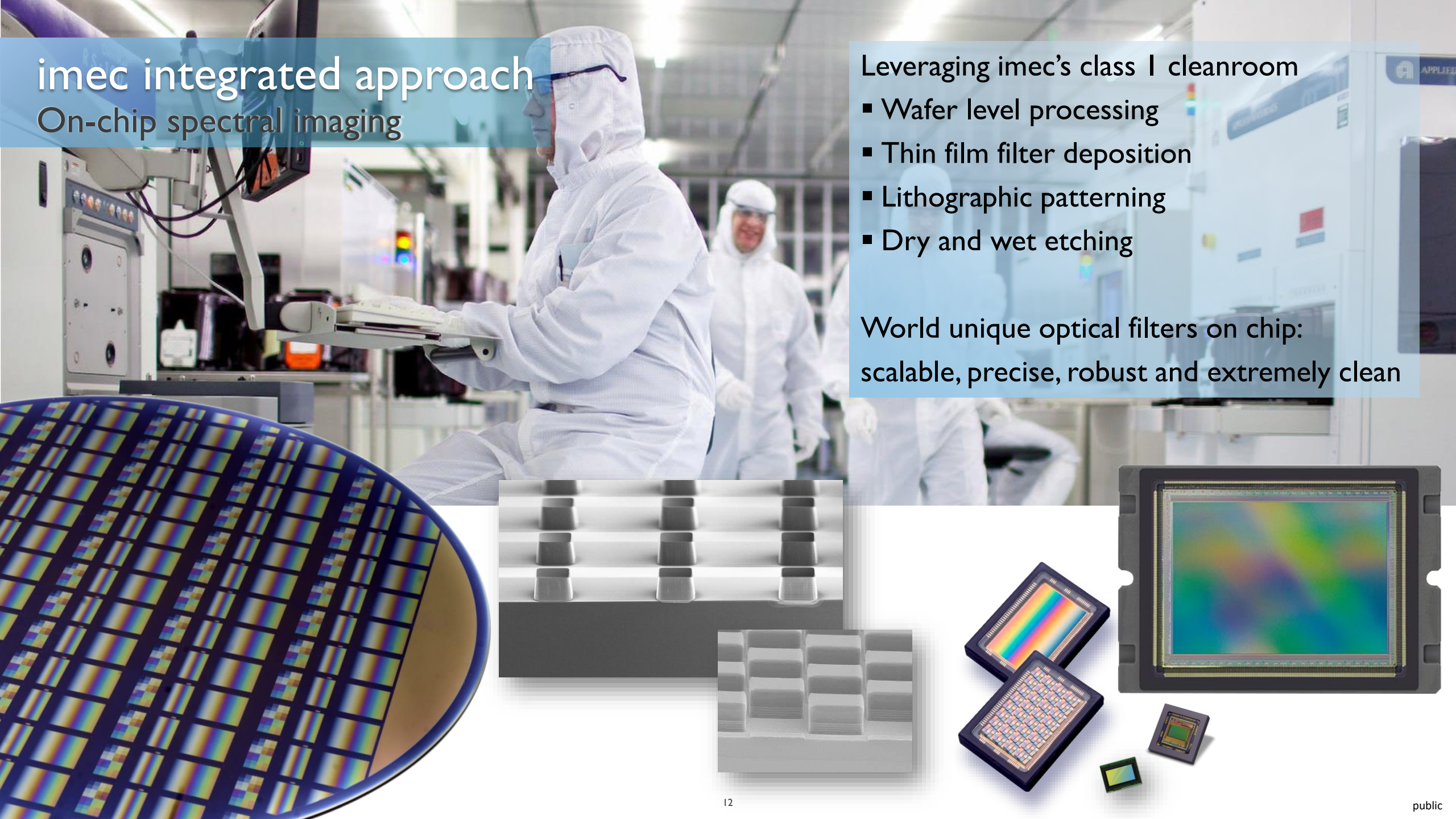

New developments, **new capabilities**

New tools allow more complex filters with reduced process complexity

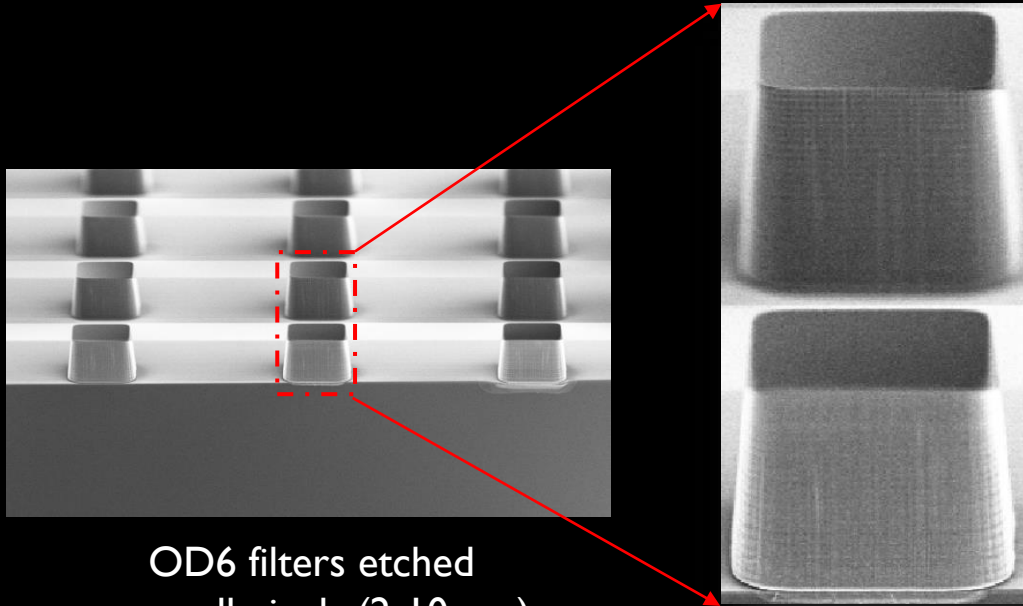

OD6 filters etched on small pixels (2-10 μm)

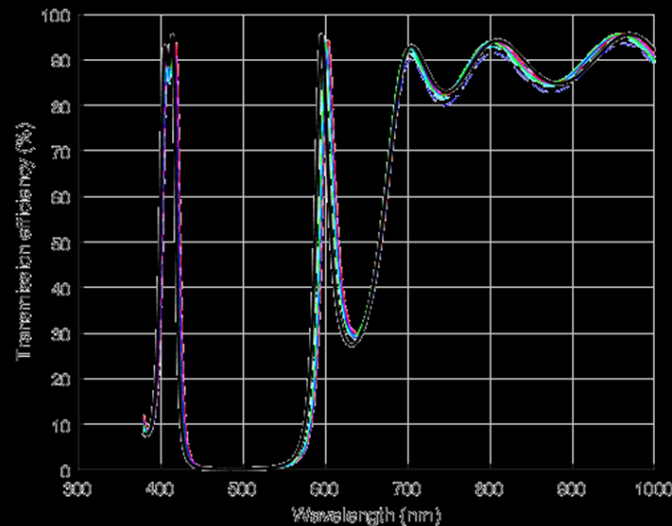
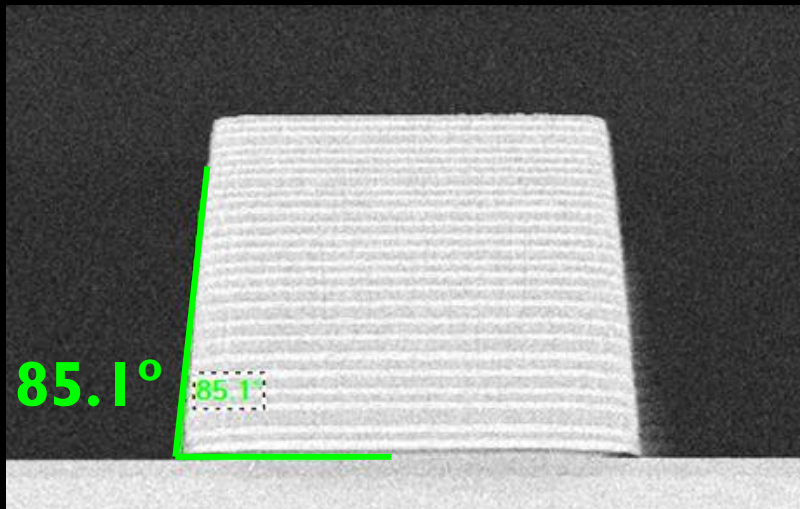
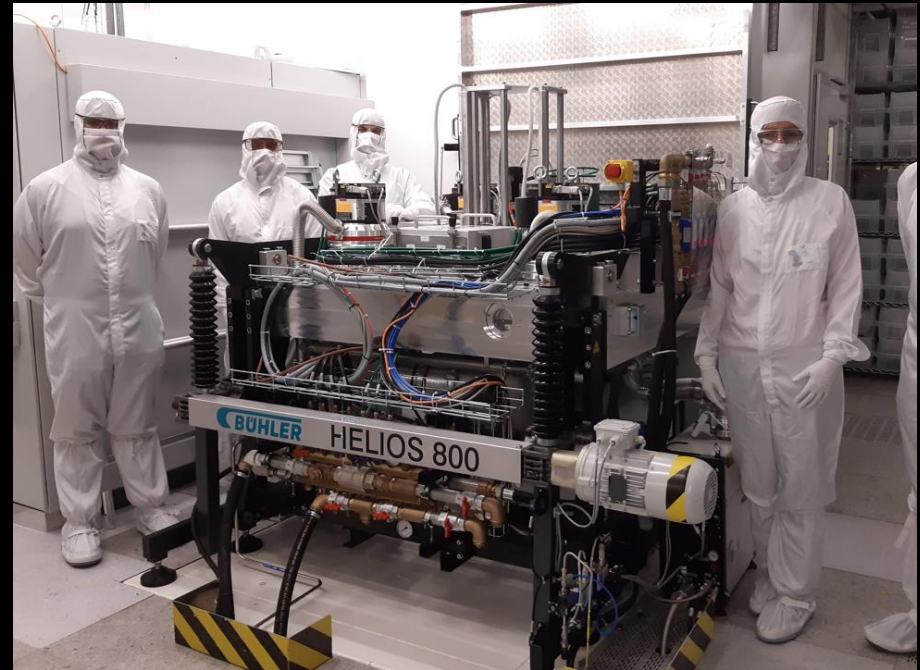

Optical tools, CMOS fab qualified

Controlled material deposition and enhanced patterning

Accurate and repeatable process

CMOS made filters applied to image sensor wafers

Accurate, mass manufacturable and extremely compact

200 mm

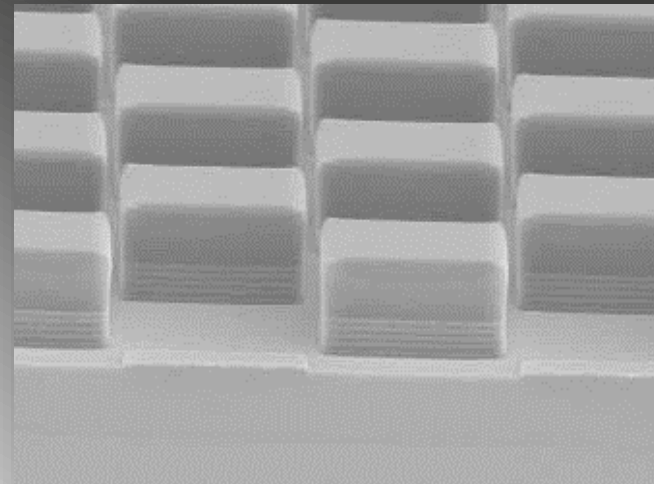
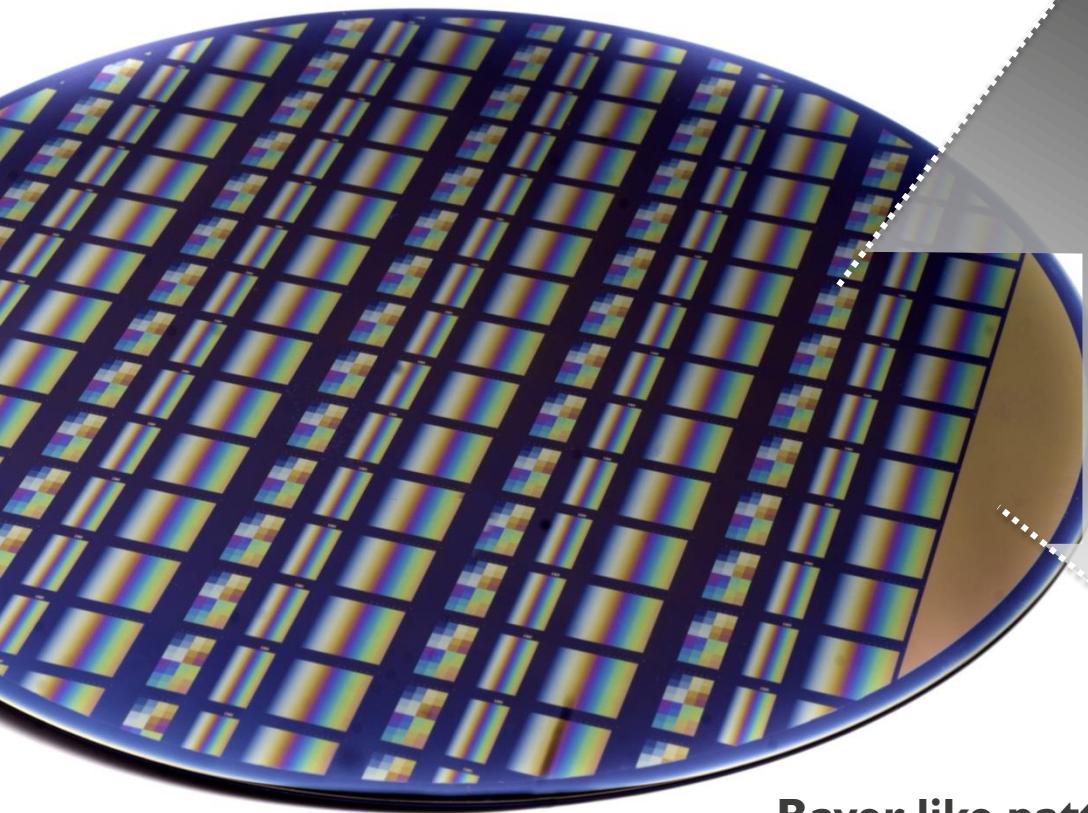

465 nm	546 nm	586 nm	630 nm
474 nm	534 nm	578 nm	624 nm
485 nm	522 nm	562 nm	608 nm
496 nm	510 nm	548 nm	600 nm

Bayer-like pattern with spectral filters

4x4 mosaic = 16 spectral bands
~ x16 cameras on-chip!

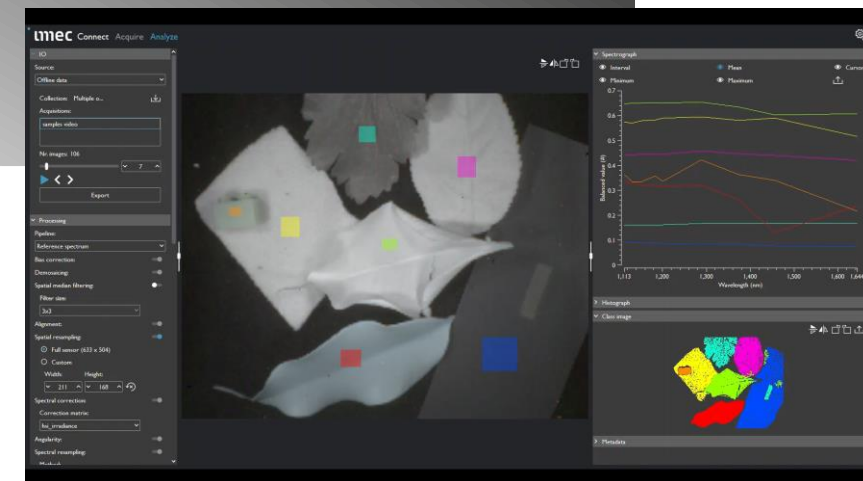

Cross section of RGB+NIR multispectral image sensor

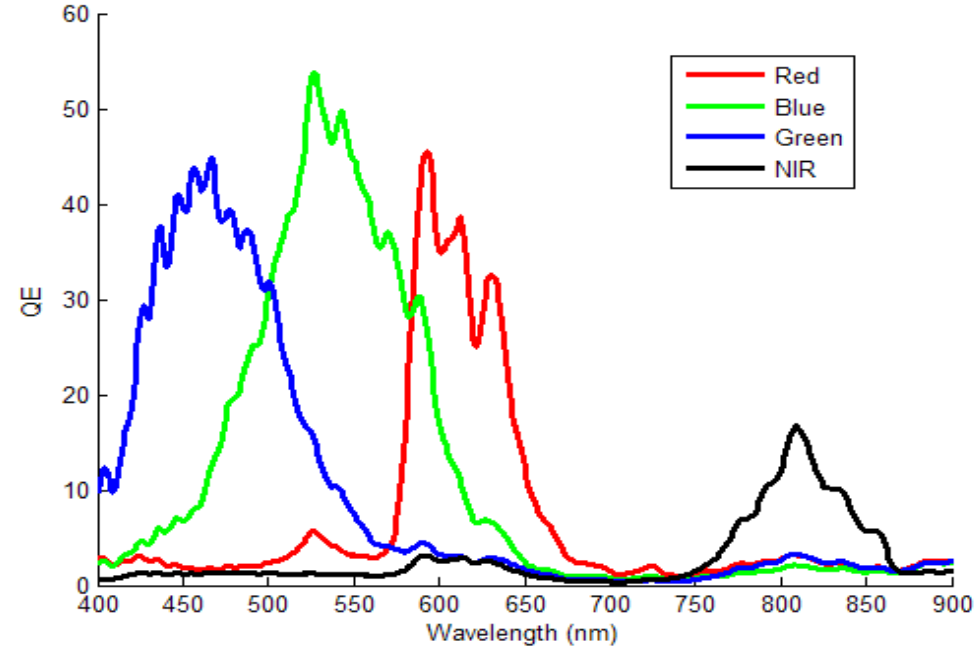
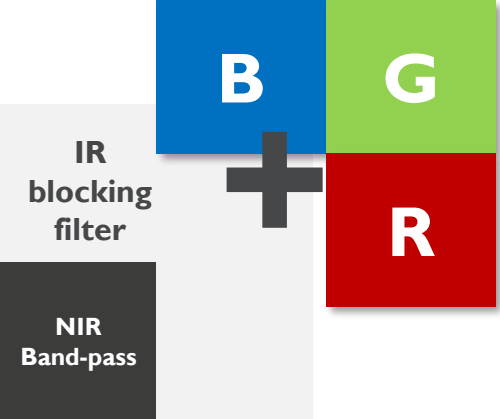
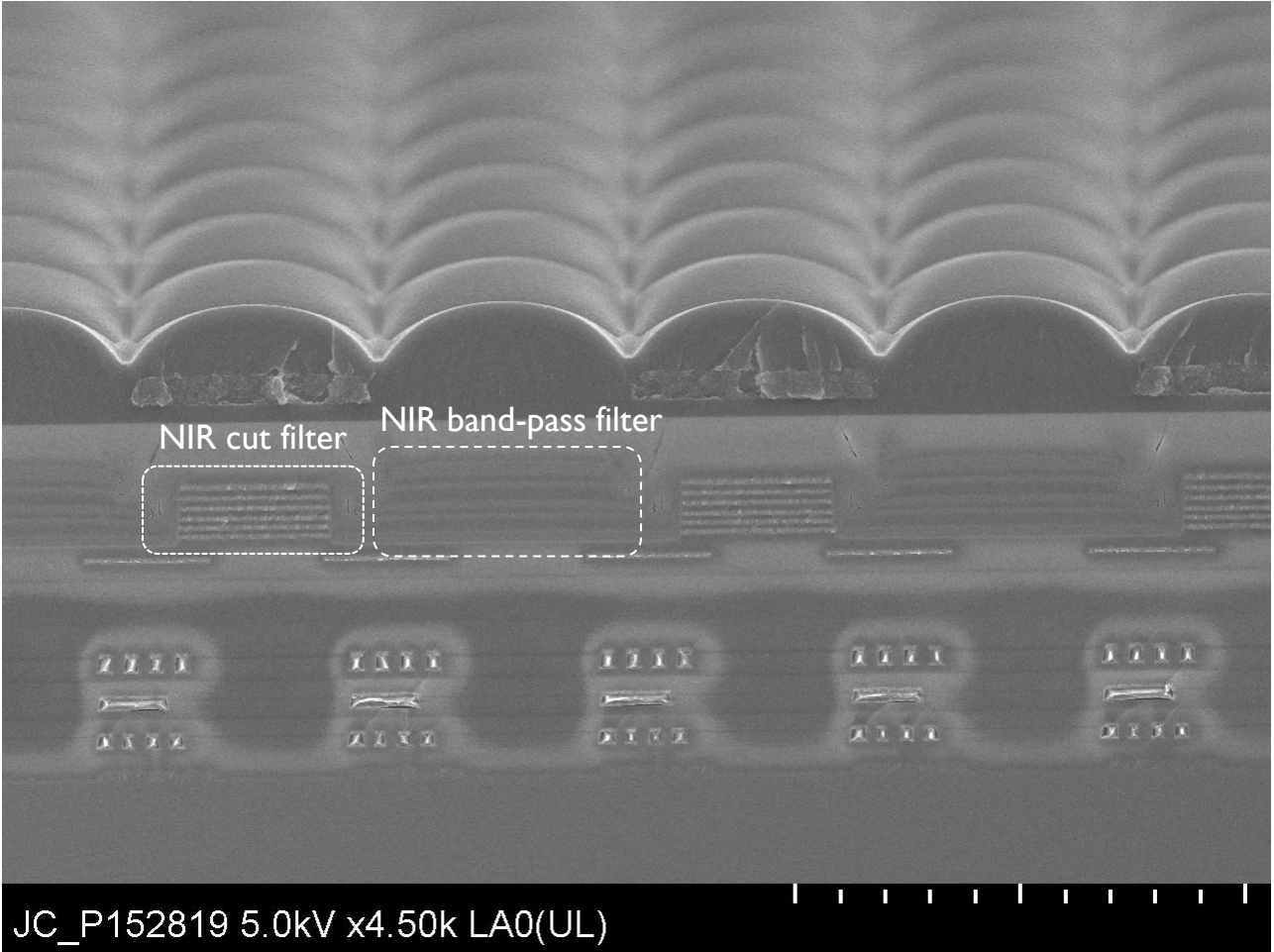

IMEC approach

patterning solutions

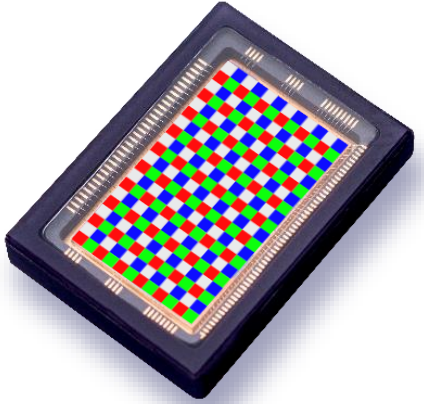
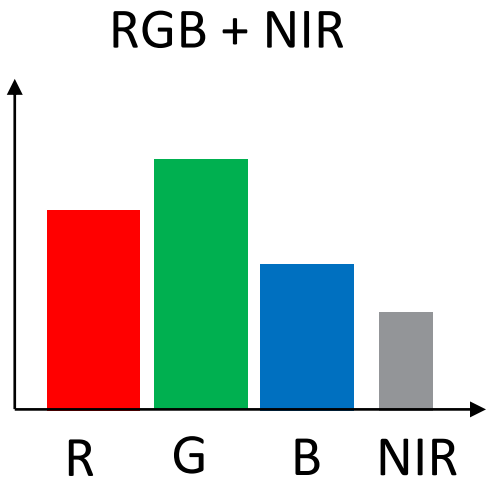

Snapshot
4 bands

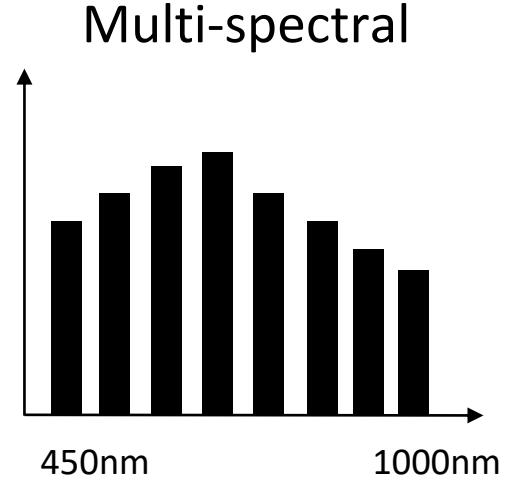

Snapshot mosaic & tiled
16 / 25 / 32 / 40+ bands

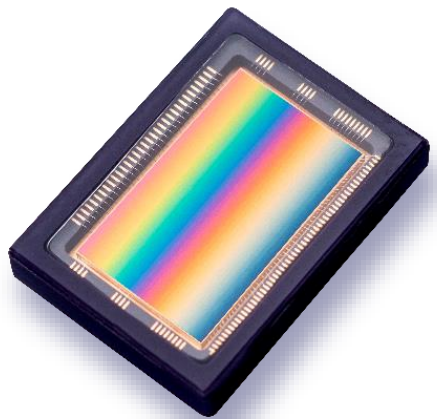
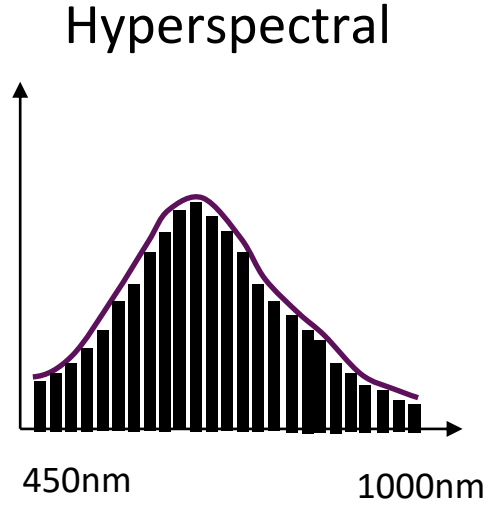

Linescan
100 / 150+ bands

Advanced filter design

Leveraging imec's process technology

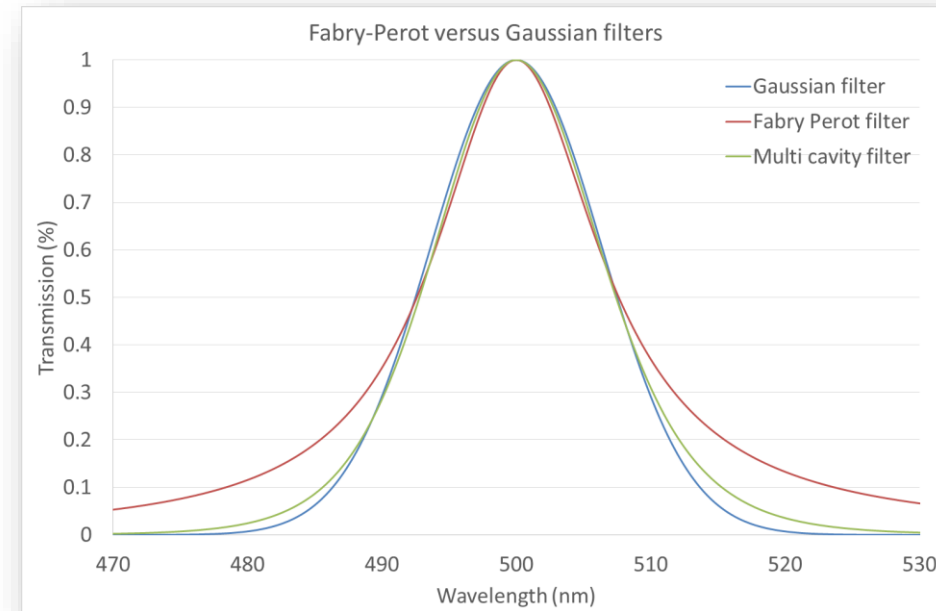
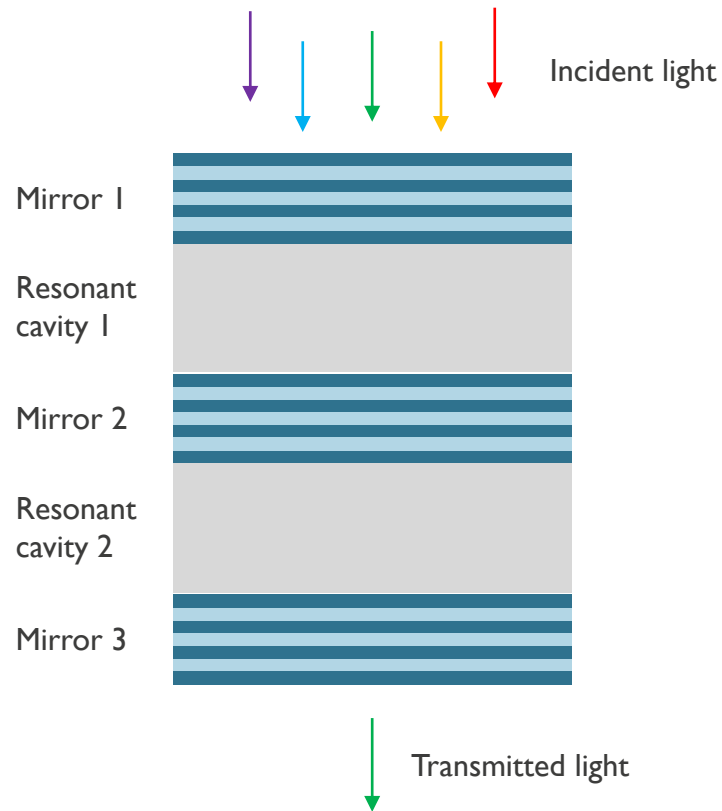

50% increased in-band signal

Wider bands (FWHM) possible

OD out of band increased 5x

Uniform OD over full sensor range

Enhanced contrast and spectral sensitivity

Robust for low light conditions

Exploiting our accurate deposition process

- Integration on chip for **decreased complexity**
- Efficient use of the focal plane for **enhanced performance**
- **Extreme design flexibility**: lines, mosaic, ...
- Optimised filter designs for **computational imaging**

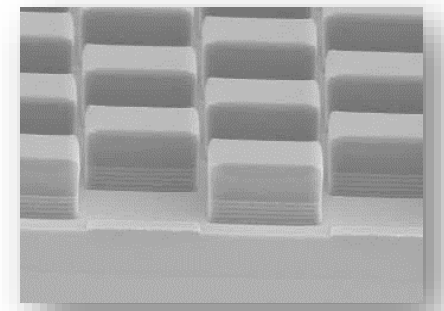
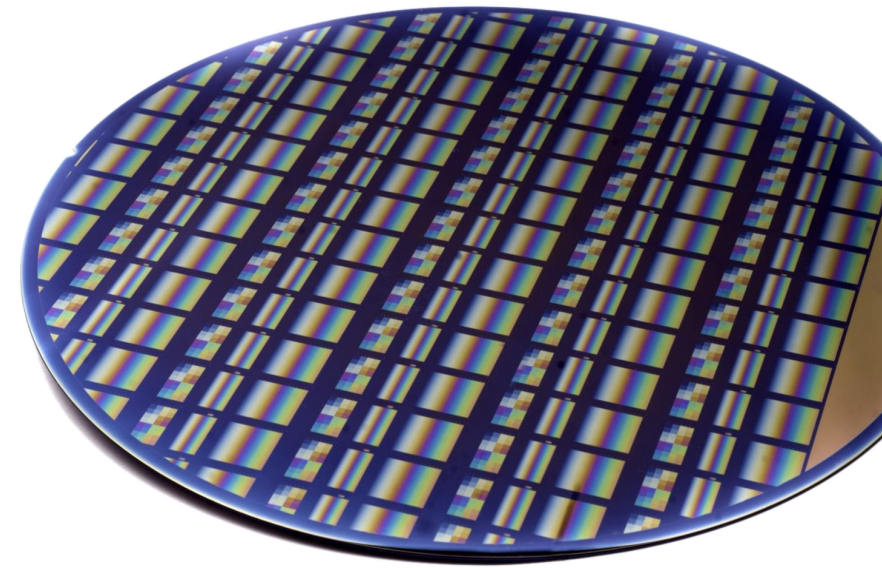

Integration on chip for decreased complexity

Sentinel 2

Mechanical integration
Interface opaquing for alignment and stray light mitigation



Filters

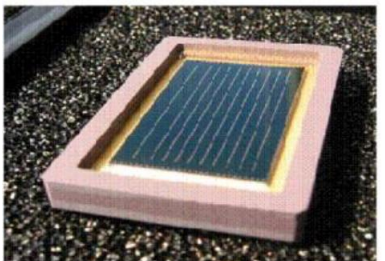

Detector



Mechanical integration

CHIEM

Robust integration on chip

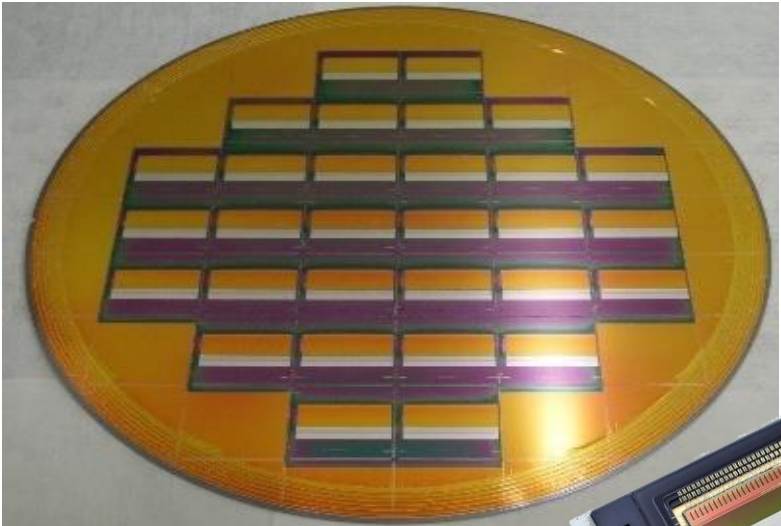

Fully integrated with detector

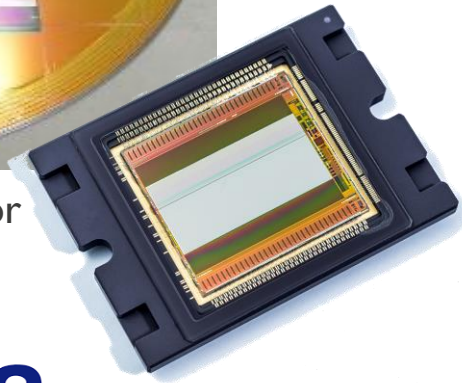



Efficient use of the focal plane for enhanced performance



First light images

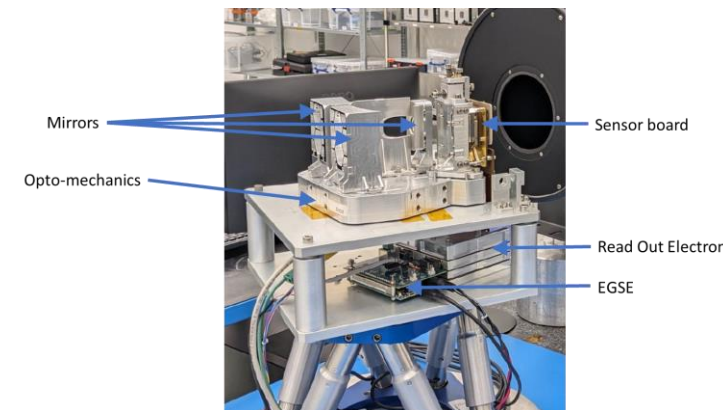
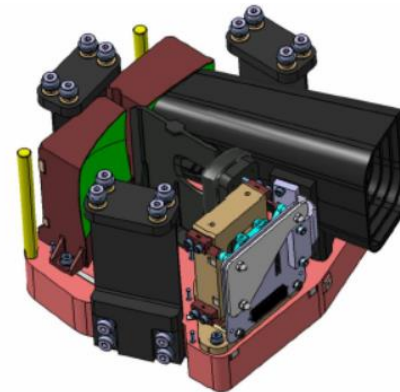
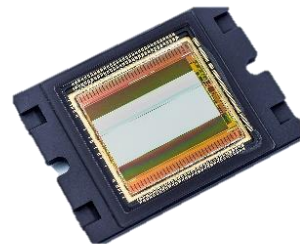
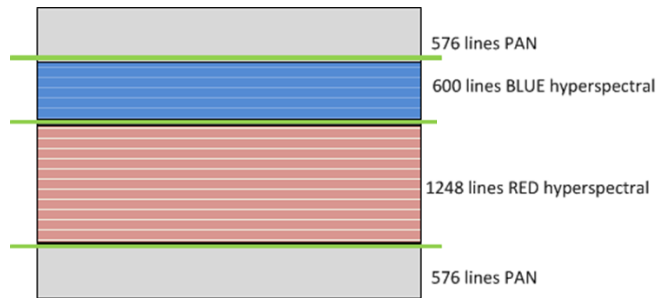
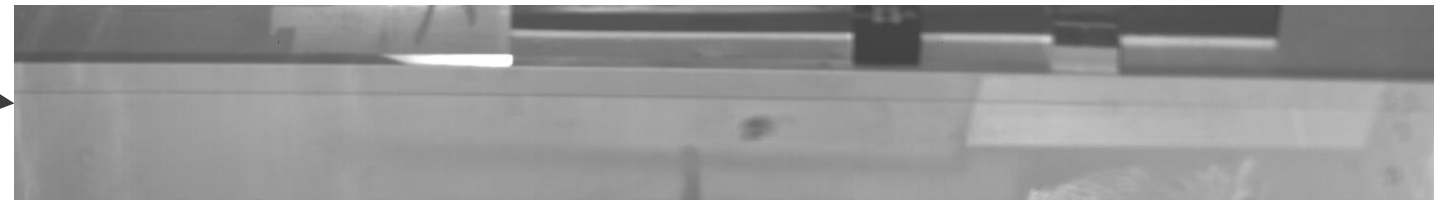

- 154 spectral bands
- 12 TDI lines per band for enhanced SNR
- Panchromatic zone for high resolution reference image

Optimised filter designs for computational imaging

Compressed sensing

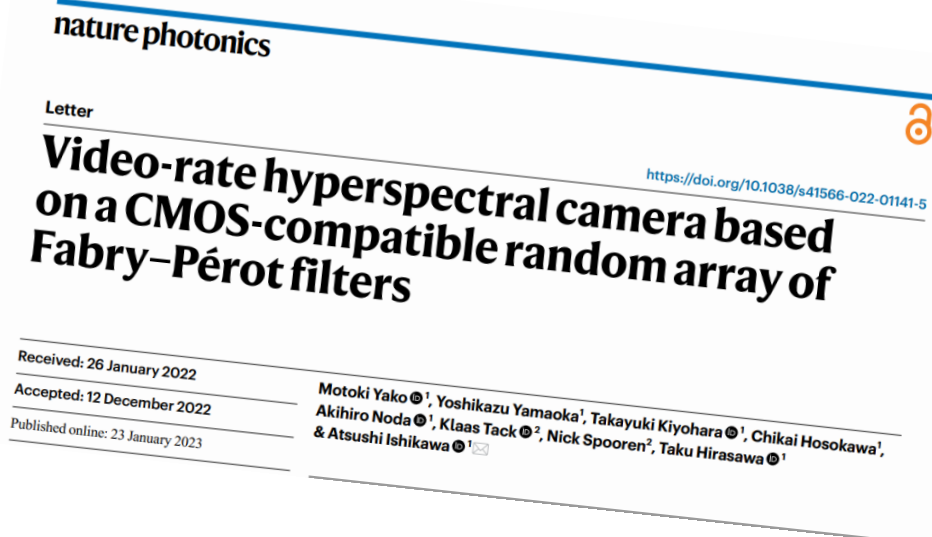
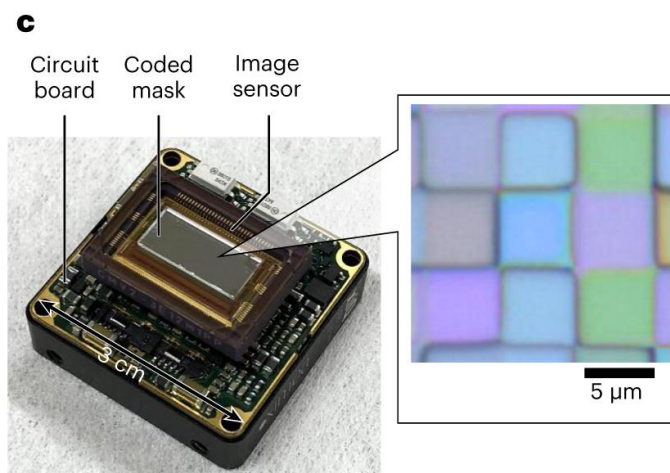
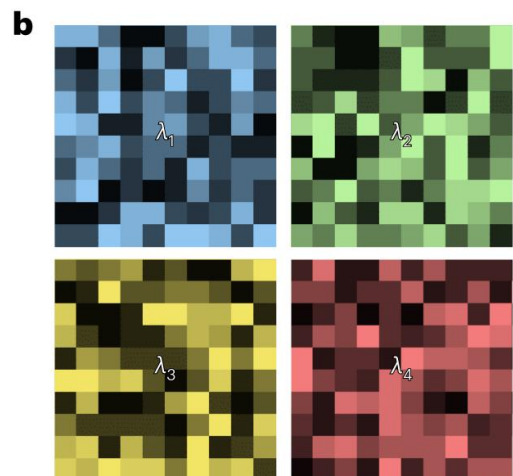
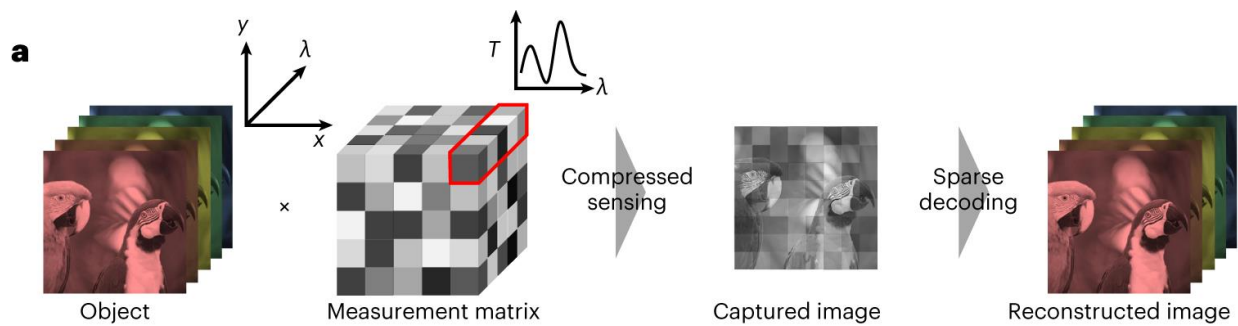

Beyond earth observation

Space exploration on rovers and robots

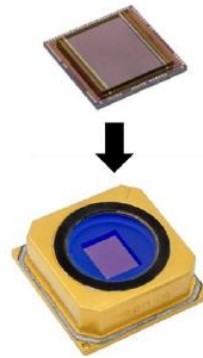

False color image

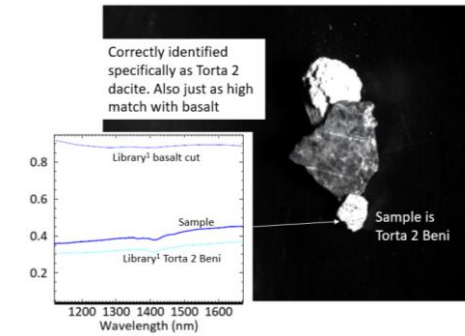

Classified image (SAM)

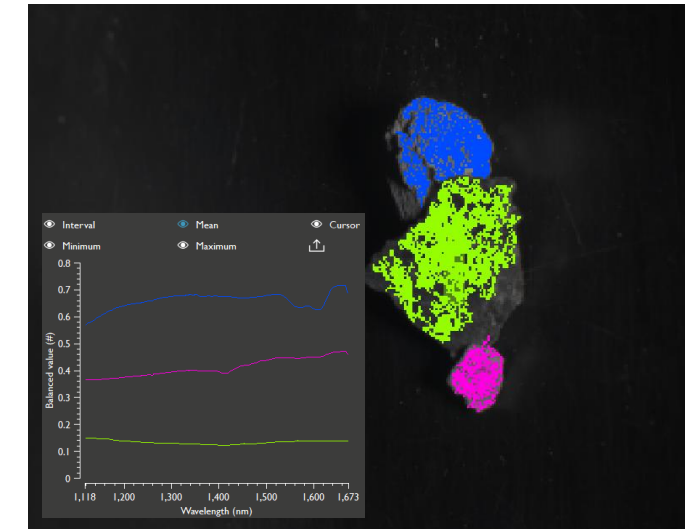

imec on-chip spectral imaging

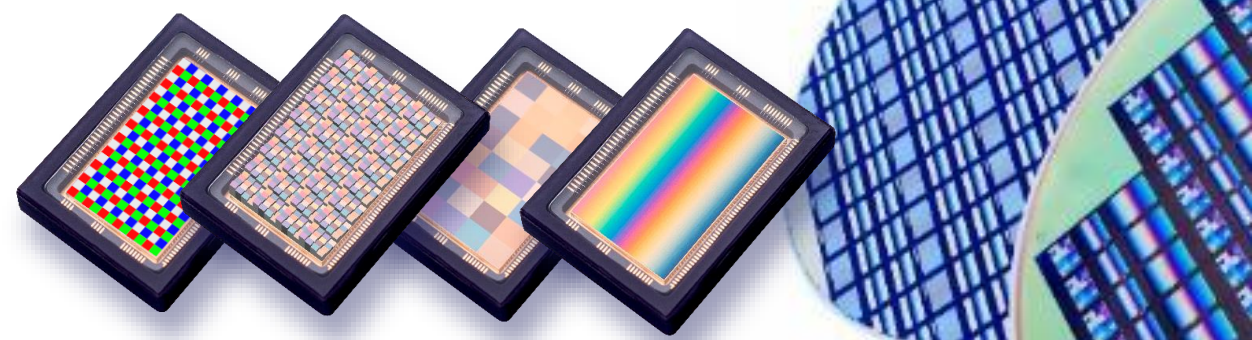

- Our unique filter deposition technology opens new opportunities for imaging from space
 - Integration on chip for **decreased complexity**
 - Efficient use of the focal plane for **enhanced performance**
 - **Extreme design flexibility**: lines, mosaic, ...
 - Optimised filter designs for **computational imaging**
- Eager to discuss how to support your **exciting space endeavours**



bavo.delaware@imec.be





mtec

embracing a better life