

iTHERA'S MEDICAL OPTOACOUSTIC IMAGING DEVICE

Dr. Patrick Leisching, CTO

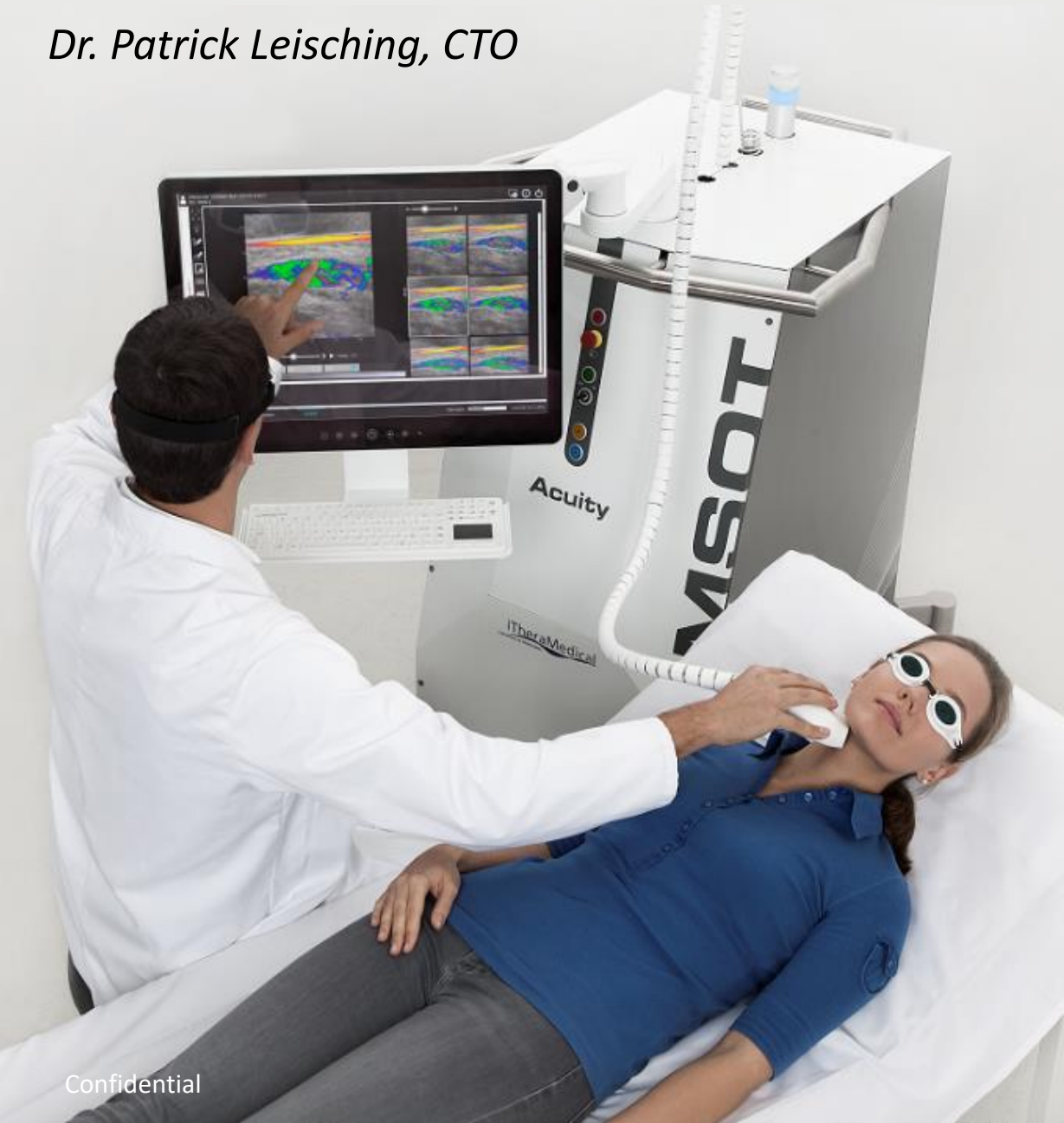

Developing & commercializing breakthrough imaging technology



Global technology & market leader for optoacoustic imaging (OAI)



Next step: Unleash technology value in routine diagnostic imaging market

MSOT IMAGE FORMATION: 'LIGHT IN, SOUND OUT'

MSOT = Multispectral Optoacoustic Tomography



MSOT

Ultrasound*

Overlay

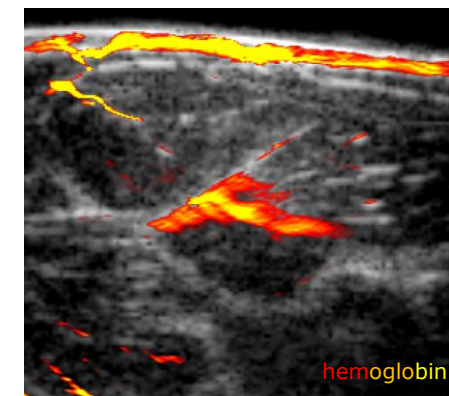
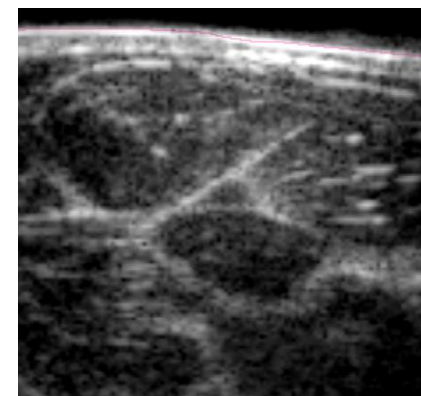
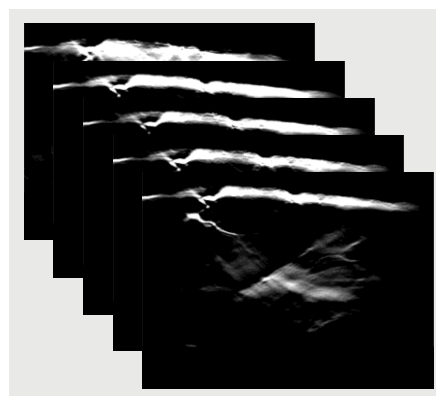
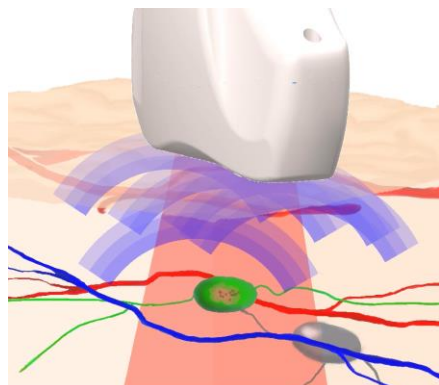
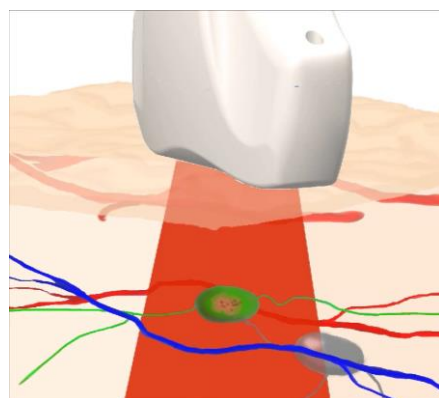

MARKET SEGMENT: MEDICAL IMAGING TECHNOLOGY

Historical improvements in imaging technology

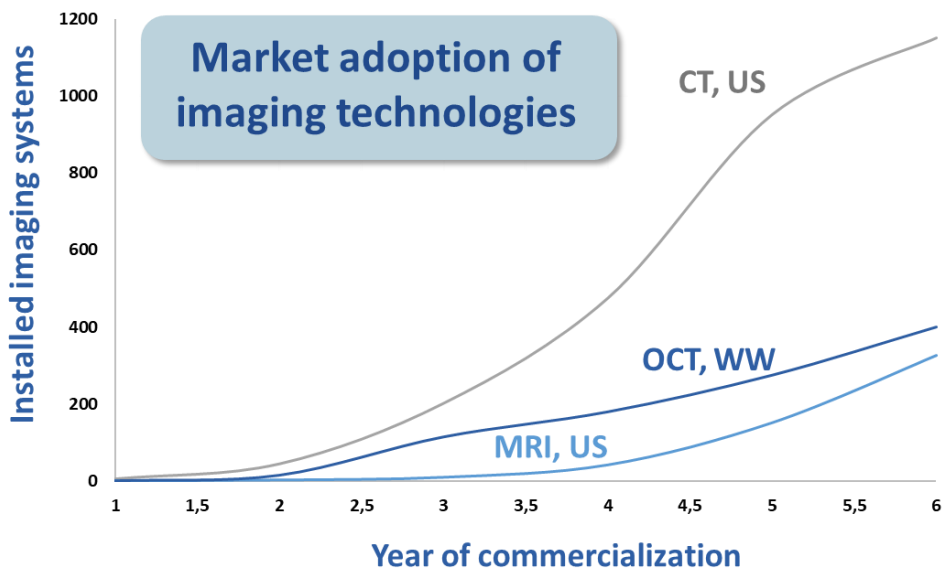
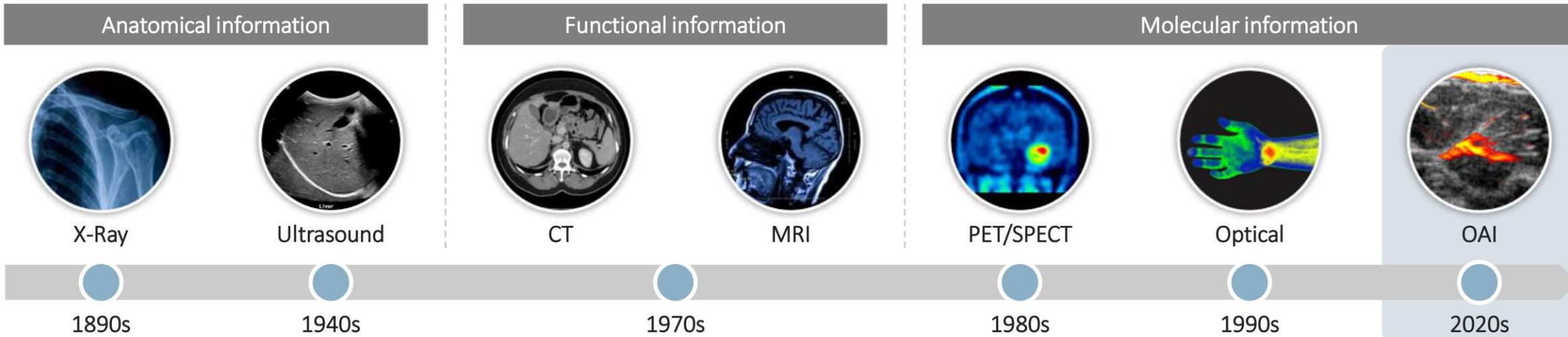

13,000
(US, 2014)⁵

>25,000
(WW, 2008)⁶

12,000
(US, 2014)⁵

**Market potential
OAI 2030**

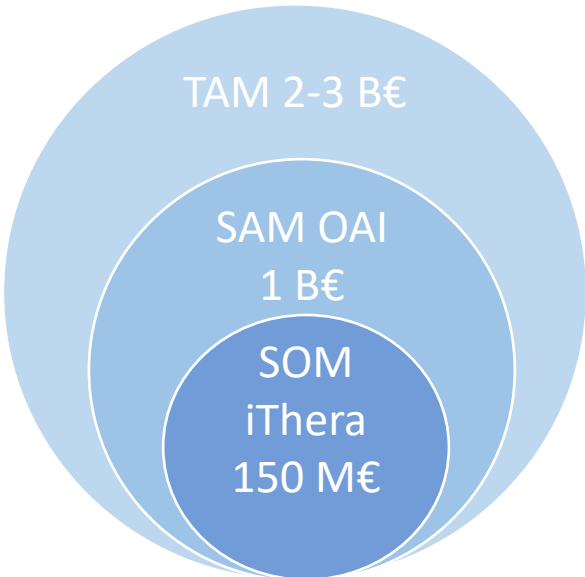

POSITIONING AND DIFFERENTIATION



CE

20 patent families
HGMU excl. licence



Proven product & IP

First scanner launched in 2012
Used broadly for clinical research
CE mark in 2019 and 2021

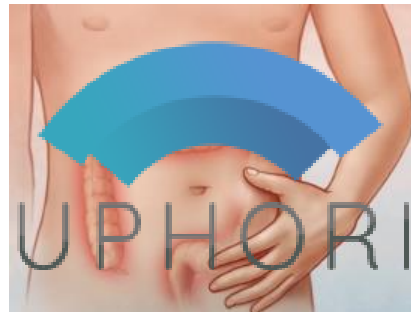

Strong clinical data

>50 clinical proof-of-concept trials
Multiple high-impact publications
1st regulatory trial ongoing



Key opinion leaders

>120* systems sold and installed
(>40M€ sales in total)
Strong base of KOL users
Equal split across USA, Europe, Asia

LIMITED COMPETITION IN CLINICAL OAI TO DATE



Only two OAI companies with active clinical program

- **Seno Medical:** only other company with CE-marked product (*Imagio*); FDA 2014-2021
- **Luxonus:** spin-off from Canon; only active in Japan



- **Mindray** only med tech corporate with active OAI program (reportedly NMPA submission in China)
- Other major imaging OEMs more likely to enter through acquisitions than own R&D (exit option)

WHAT DO WE LOOK FOR?

2010-2020: Feeding the emerging market, expanding IP portfolio

- Complex and bulky OPO laser systems, low wall-plug efficiency
- 20 patent families, 2014: Deutscher Innovationspreis
- 2019: CE mark

2021-2024: Scale & leadership in maturing market

- Compact OPO laser system with bundled fiber array for delivery
- FDA & clinical trials
- CAGR +47%, >10 M€ revenue 2025

2025-2030: Prepare for wide market entry

- Diode based laser system with optimized bundled fiber array for delivery
- Routine clinical use
- CAGR +47%, >100 M€ revenue 2030

WHAT DO WE LOOK FOR?

Laser system: 650-1300 nm, 10 mJ, 10 ns, 25-100 Hz, < 300 W

Fiber delivery: circular 5 mm / 300 fibers to flat top hand-held (70% efficiency)

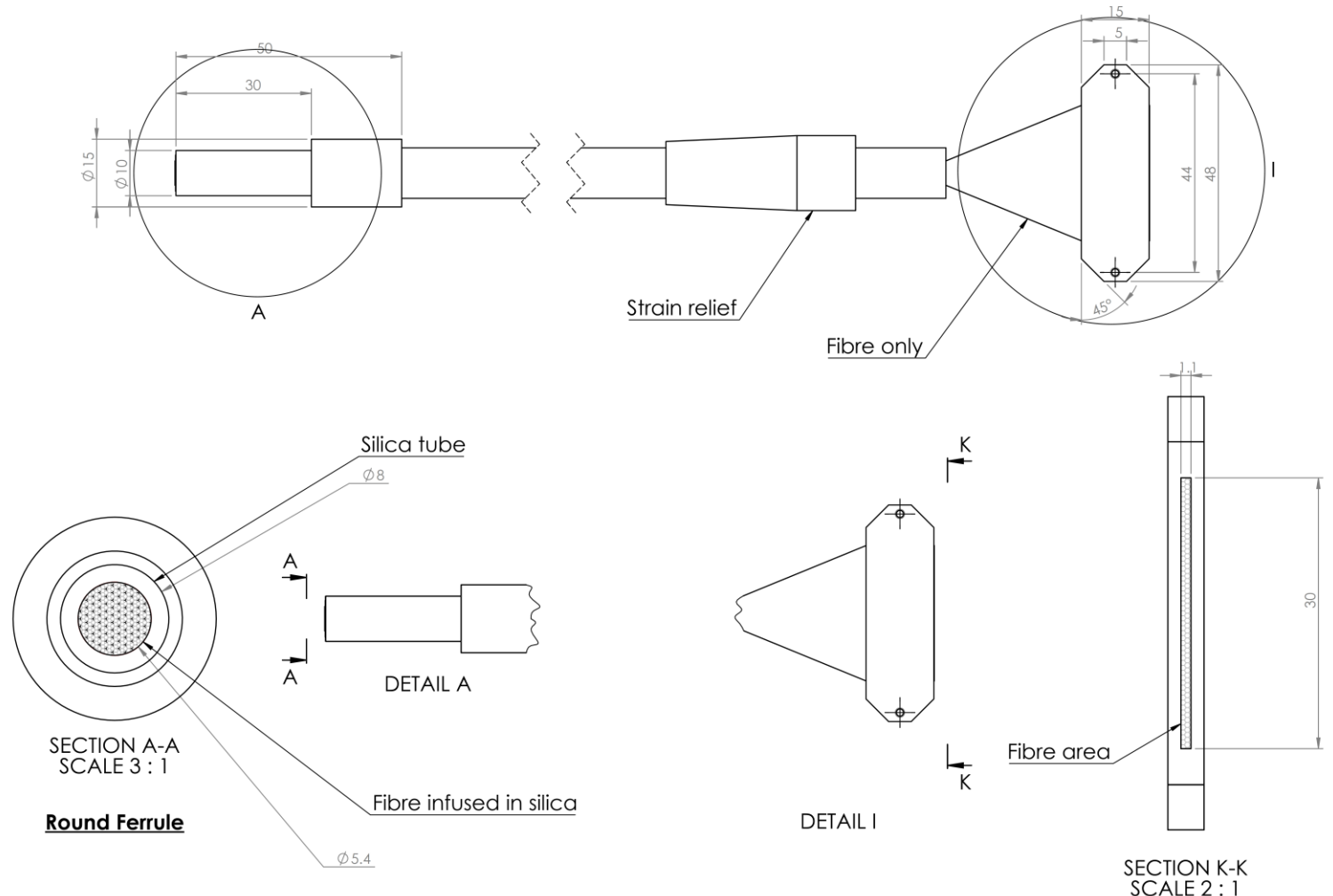

PARTICIPATE IN AN IMAGING REVOLUTION.

Optoacoustics, the next generation in biomedical imaging.

Christian Wiest
CEO

+49 176 6373 6108
christian.wiest@ithera-medical.com

Philipp Bell
CCO

+49 172 481 4722
philipp.bell@ithera-medical.com

Patrick Leisching
CTO

+49 175 265 4785
patrick.leisching@ithera-medical.com