

Nanosystems and  
Technologies  
GmbH

**nanoplus**

# EPIC Online Technology Meeting on Mid-IR Technologies for Environmental Monitoring

  
**Sensalight  
Technologies**



**2021**

**Dr. Johannes Koeth, CEO**  
nanoplus GmbH  
Nanosystems and Technologies  
Oberer Kirschberg 4  
D-97218 Gerbrunn

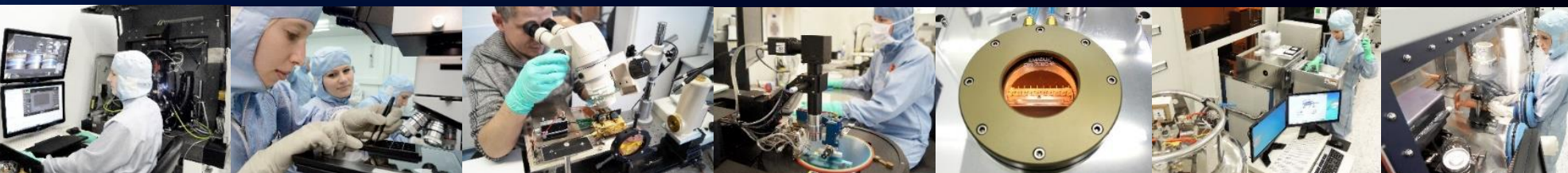
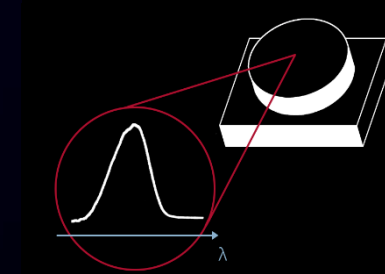
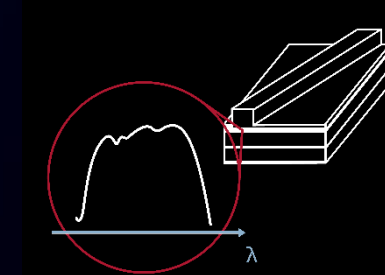
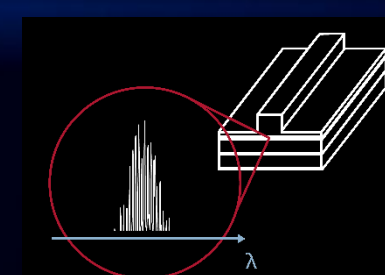
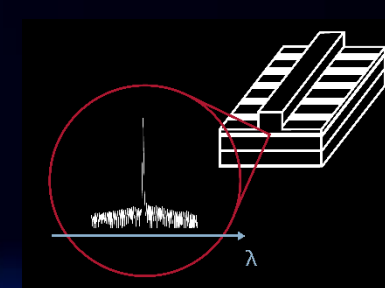
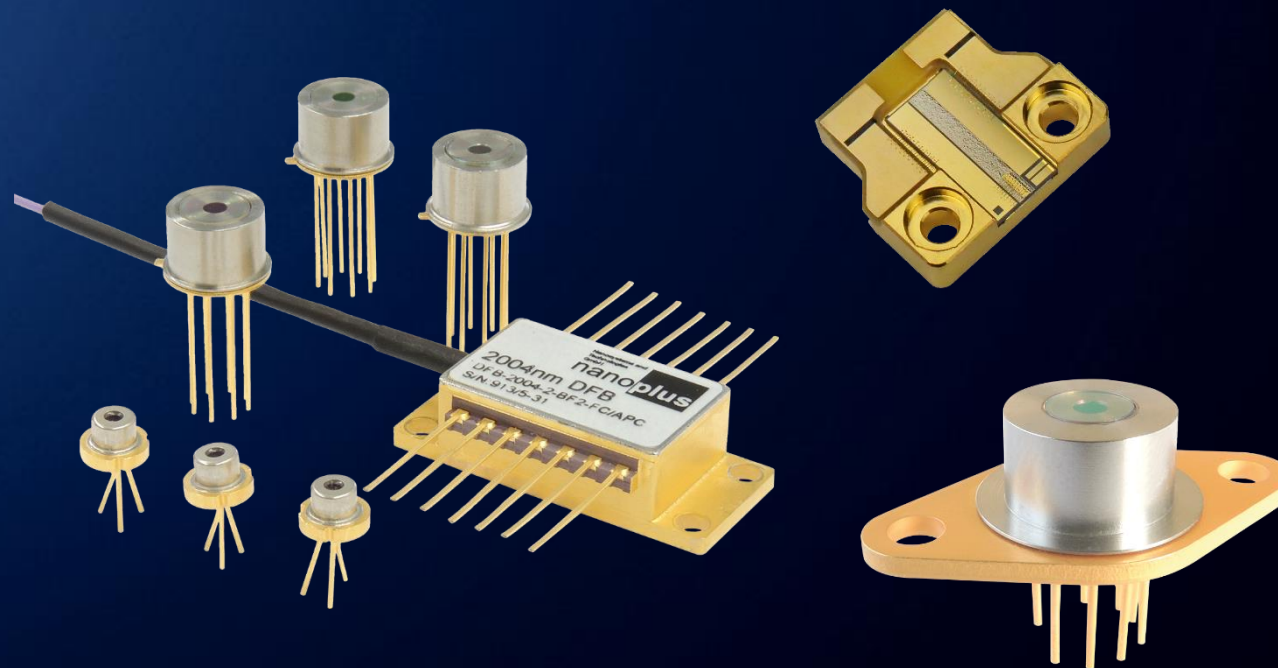

# full vertical integration

**Material  
Design  
Simulation  
Epitaxy**

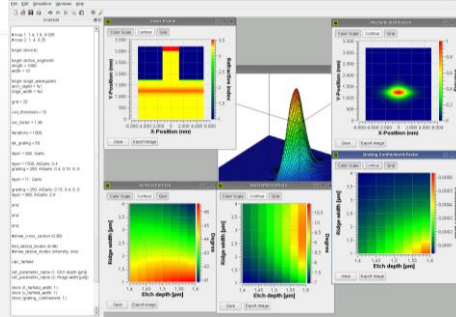

**Device Processing**

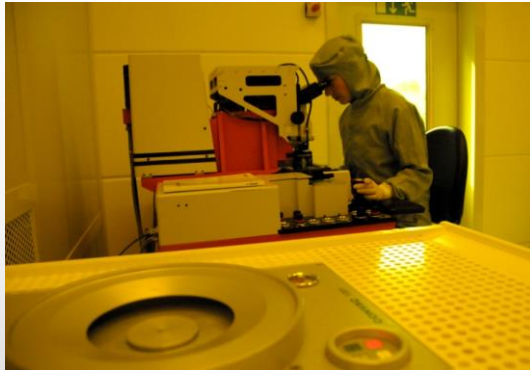

**Device mounting**

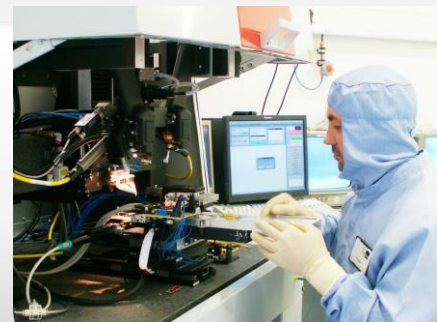

**Device Burn-In  
and Characterisation**

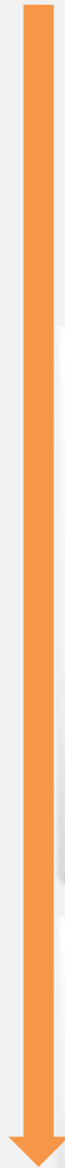

## DFB Laser

- wavelengths:  
760 nm – 14.000 nm  
(DL, ICL, QCL)
- custom specific solutions

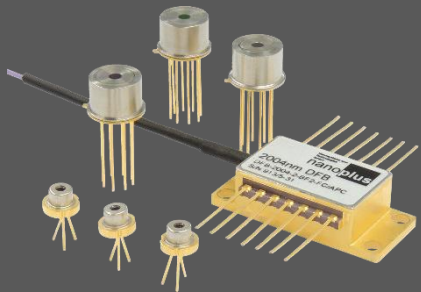
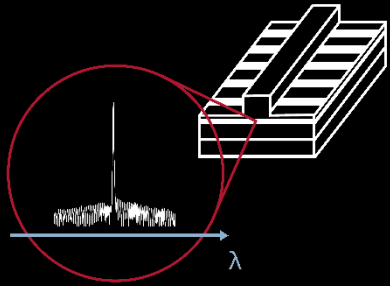

## Fabry-Pérot LD

- wavelengths:  
760 nm – 14.000 nm
- up to 1 W cw

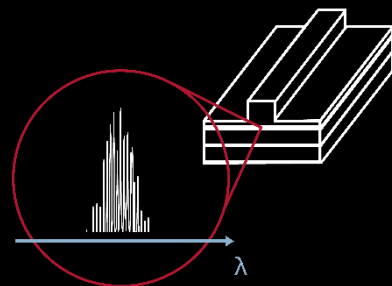

## SLD

- wavelengths:  
760 nm – 2900 nm
- cw & RT

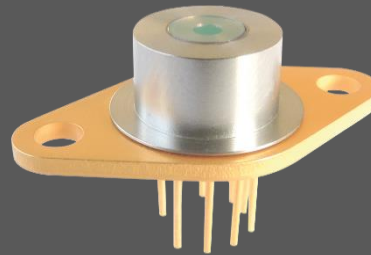
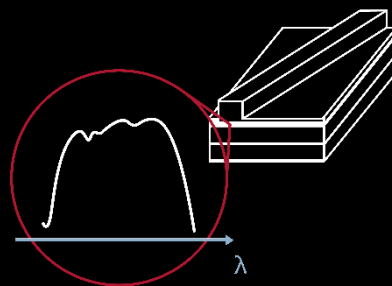

## MIR-LED

- wavelengths:  
2800 nm – 6500 nm
- cw & RT

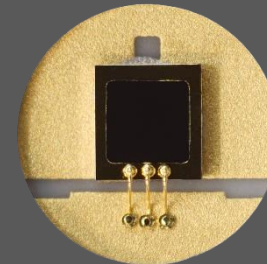
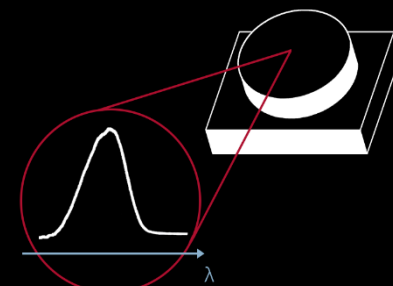

## more...

- Custom Packaging
- Collimation
- Technology Development
- Lithography Service

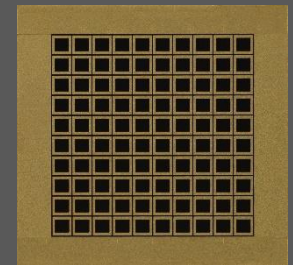
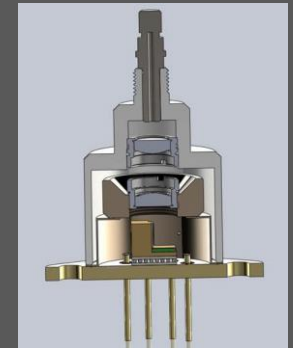

## DFB Laser

- wavelengths:  
760 nm – 14.000 nm  
(DL, ICL, QCL)
- custom specific solutions

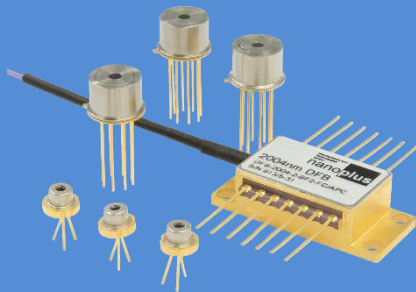
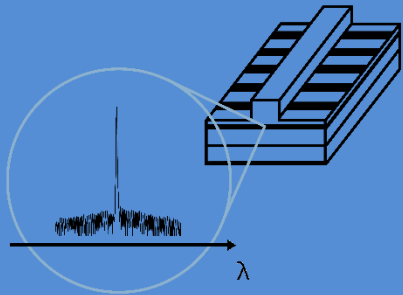

## Fabry-Pérot LD

- wavelengths:  
760 nm – 14.000 nm
- up to 1 W cw

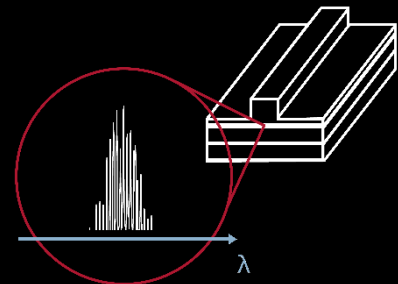

## SLD

- wavelengths:  
760 nm – 2900 nm
- cw & RT

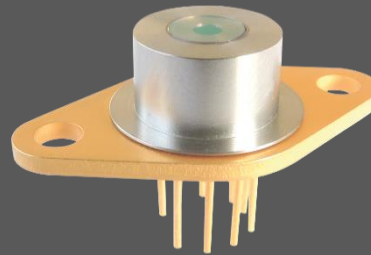
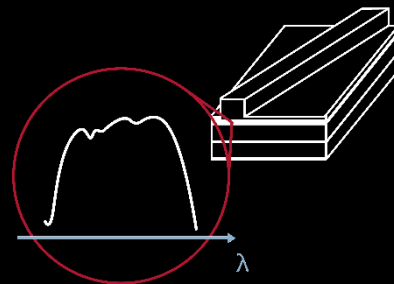

## MIR-LED

- wavelengths:  
2800 nm – 6500 nm
- cw & RT

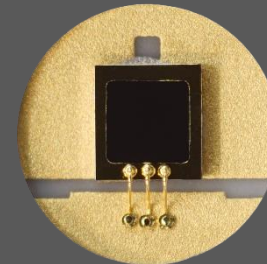
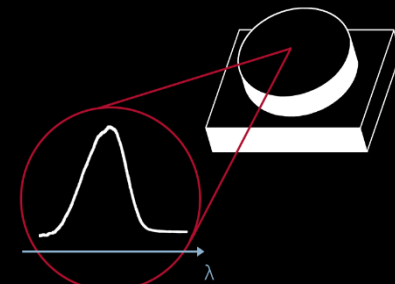

## more...

- Custom Packaging
- Collimation
- Technology Development
- Lithography Service

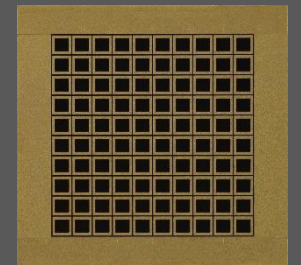
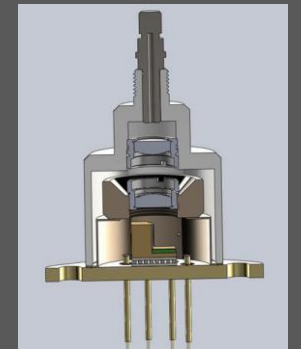

# DFB Semiconductor Laser

- Diode-Laser (DL): 760 nm ... 2900 nm
- Interband Cascade Laser (ICL): 2800 nm ... 6500 nm
- Quantum Cascade Laser (QCL): 6  $\mu\text{m}$  ... 14  $\mu\text{m}$

large tuning coefficient

high power

custom specific solutions for every wavelength

various packaging options w/wo TEC and NTC

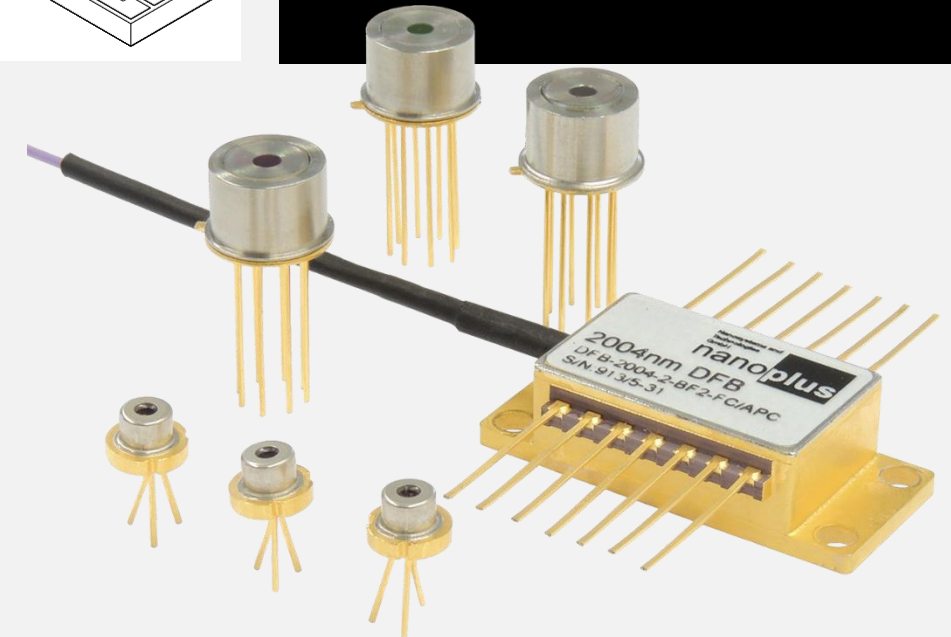
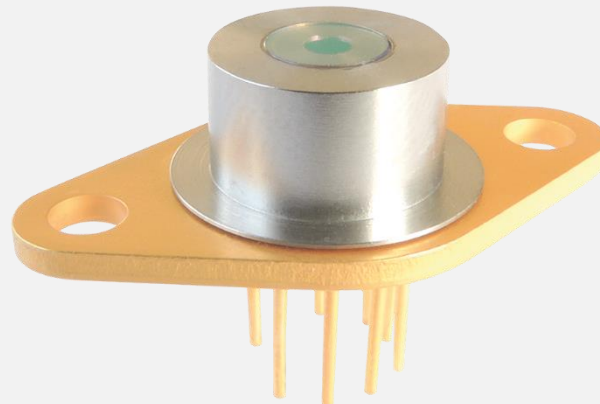
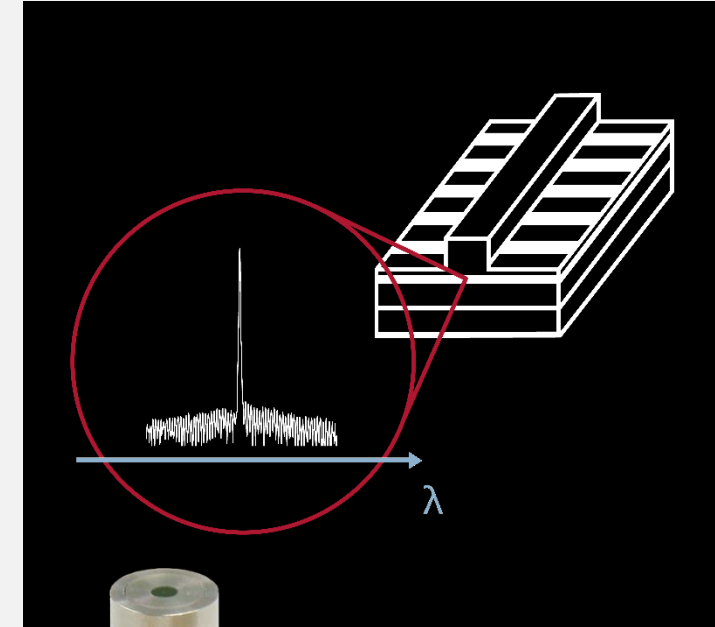
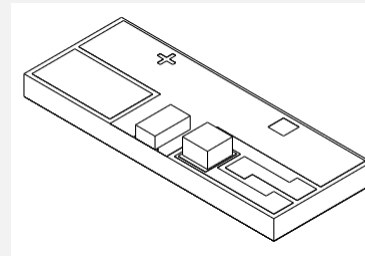

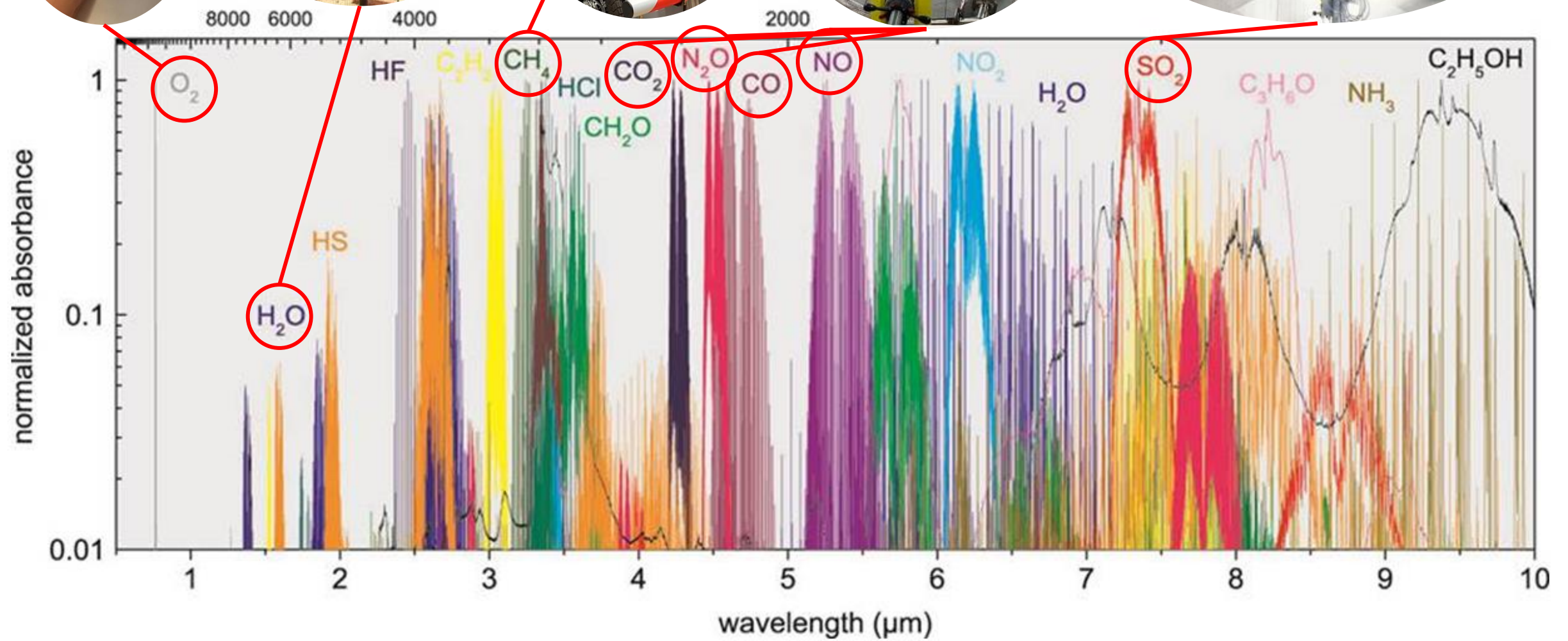
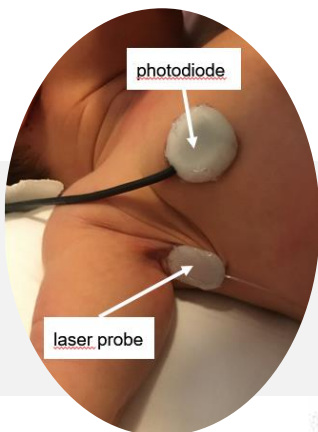

# Example: Hydrocarbons at 3.3 $\mu\text{m}$

Hydrocarbons possess significant absorption features in the interval

(3.2  $\mu\text{m}$  - 3.4  $\mu\text{m}$ )

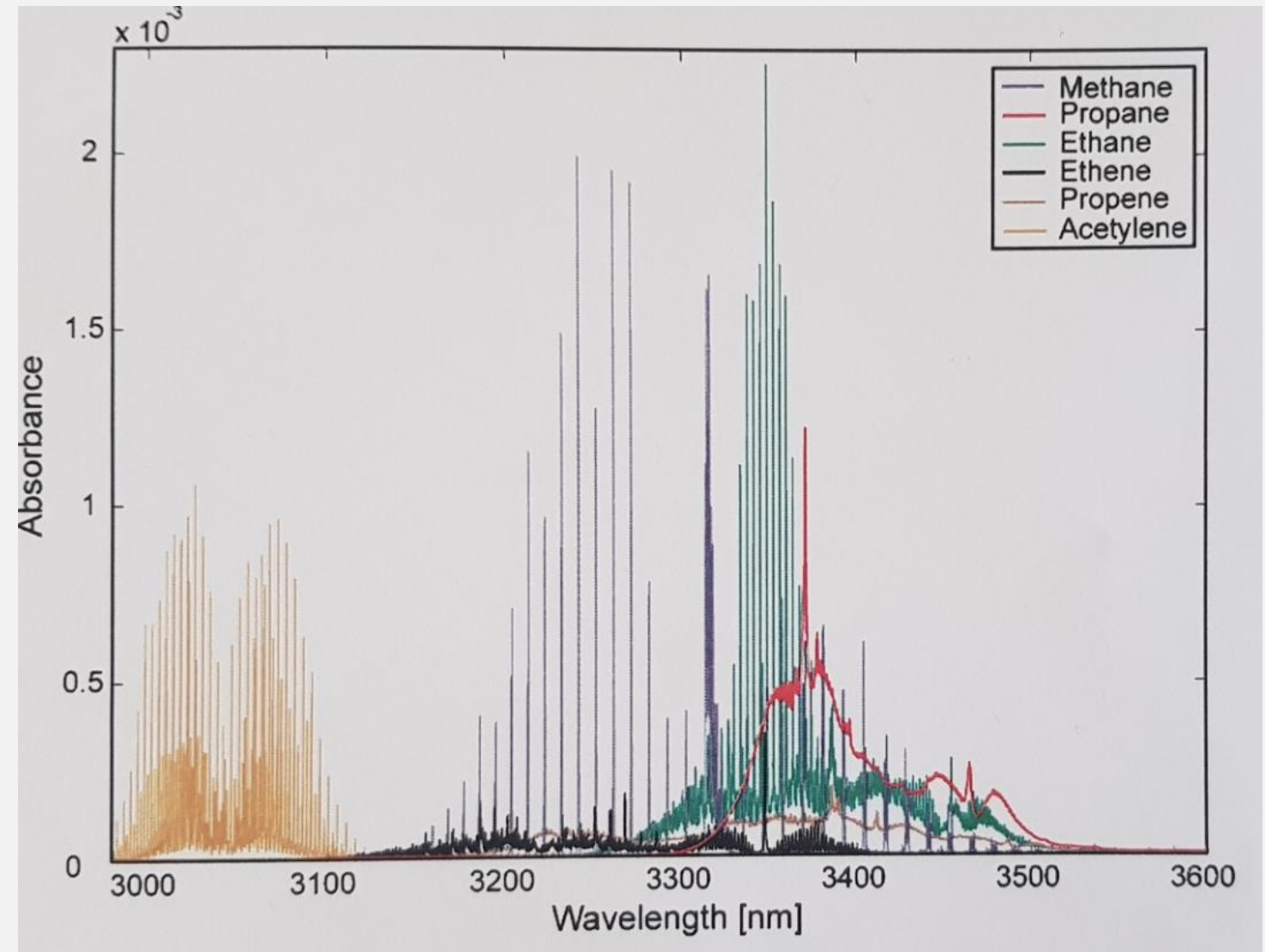

## DFB Laser

- wavelengths:  
760 nm – 14.000 nm  
(DL, ICL, QCL)
- custom specific solutions

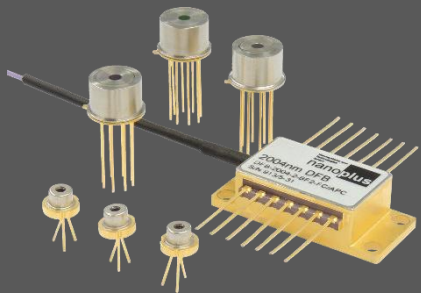
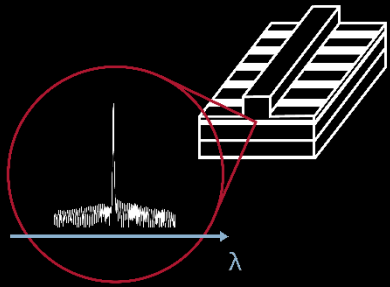

## Fabry-Pérot LD

- wavelengths:  
760 nm – 14.000 nm
- up to 1 W cw

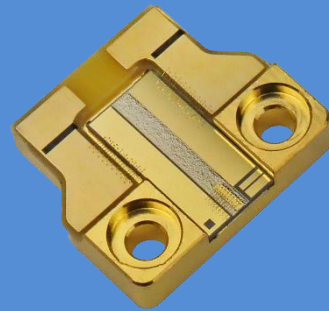
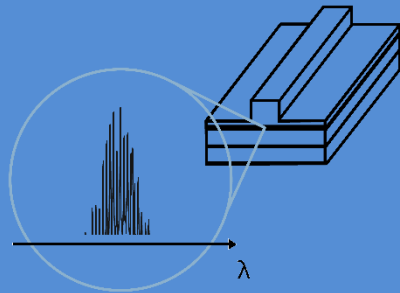

## SLD

- wavelengths:  
760 nm – 2900 nm
- cw & RT

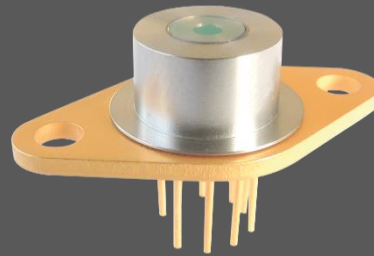
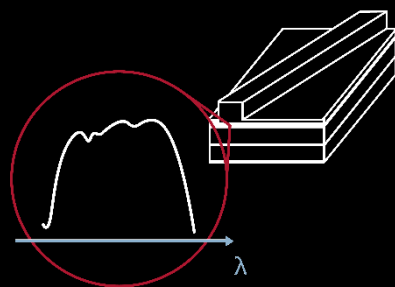

## MIR-LED

- wavelengths:  
2800 nm – 6500 nm
- cw & RT

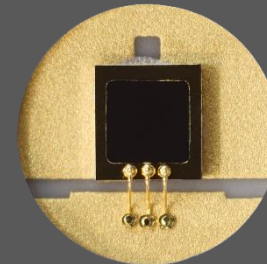
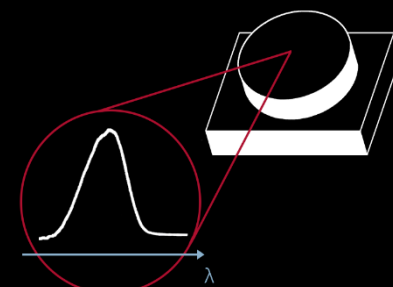

## more...

- Custom Packaging
- Collimation
- Technology Development
- Lithography Service

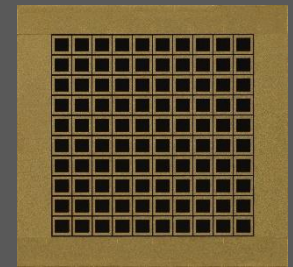
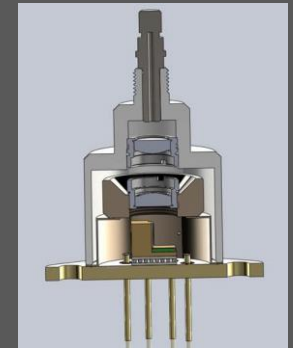



# Fabry-Pérot Laser Diode

- Diode Laser: 760 nm ... 2900 nm
- Interband Cascade Laser (ICL): 2800 nm ... 6500 nm
- Quantum Cascade Laser (QCL): 6  $\mu\text{m}$  ... 14  $\mu\text{m}$

high-power option up to **1 W**

broadband; customer-specific solutions for every wavelength  
various packaging options w/wo TEC and NTC

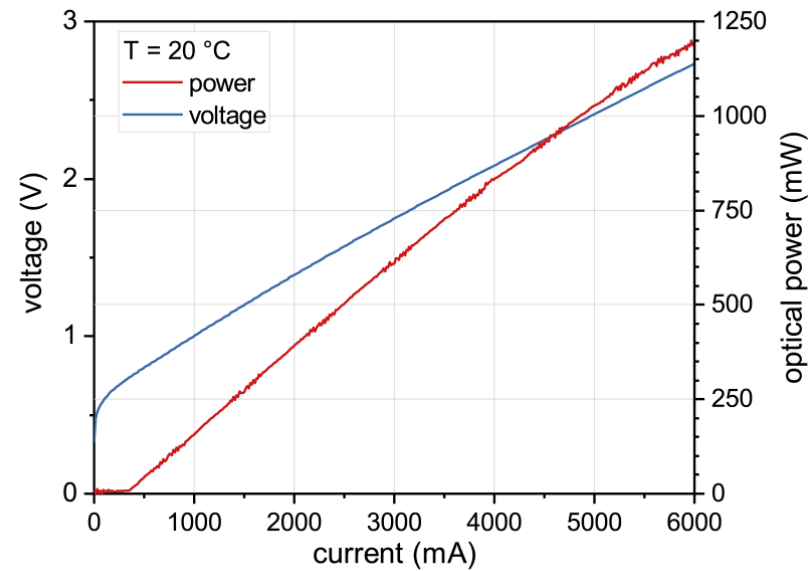
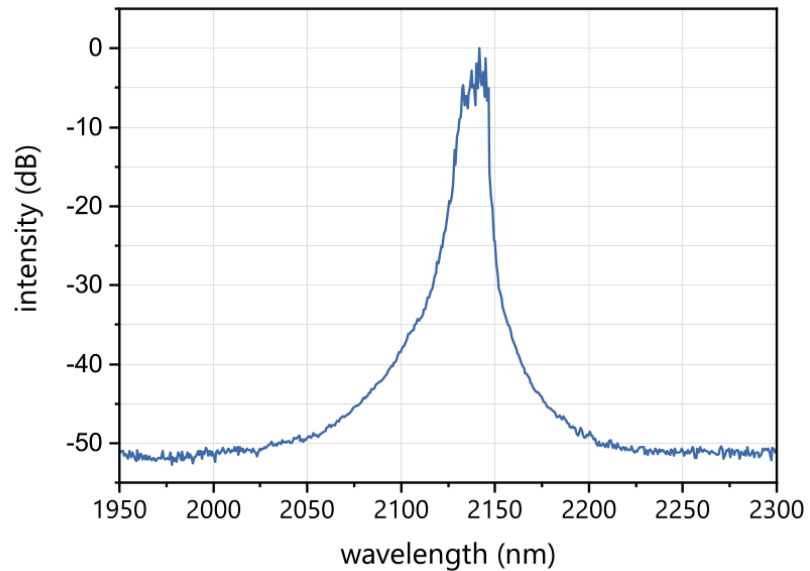
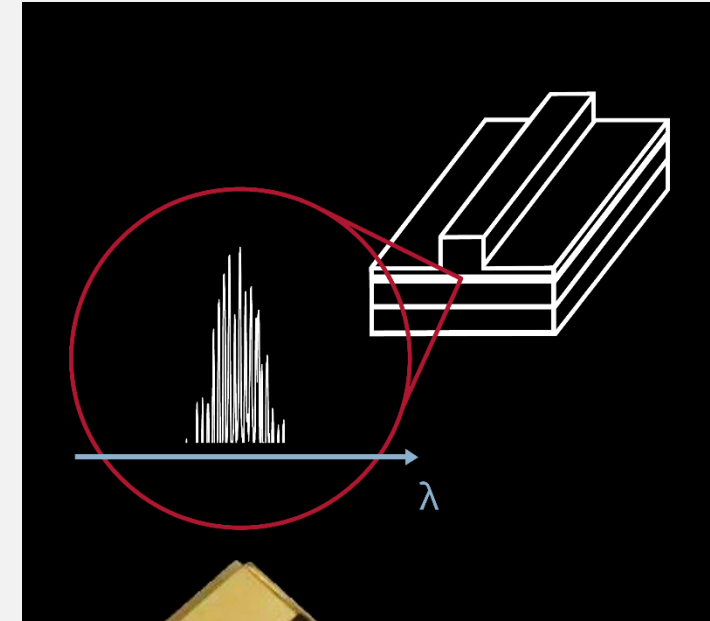

## DFB Laser

- wavelengths:  
760 nm – 14.000 nm  
(DL, ICL, QCL)
- custom specific solutions

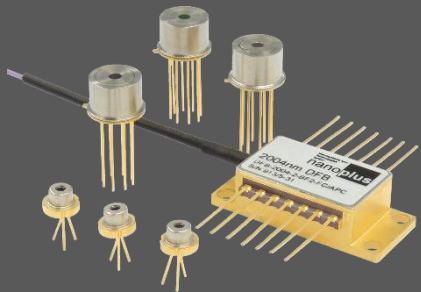
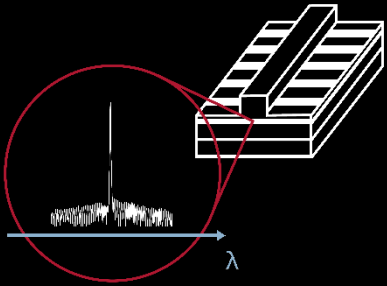

## Fabry-Pérot LD

- wavelengths:  
760 nm – 14.000 nm
- up to 1 W cw

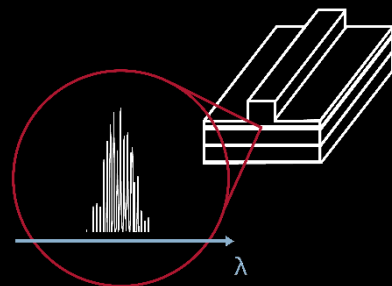

## SLD

- wavelengths:  
760 nm – 2900 nm
- cw & RT

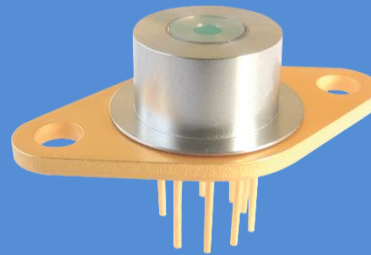
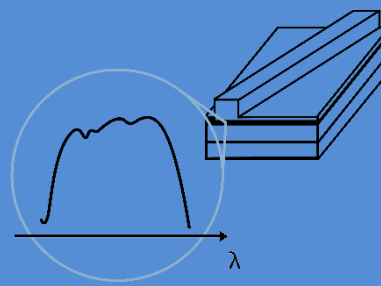

## MIR-LED

- wavelengths:  
2800 nm – 6500 nm
- cw & RT

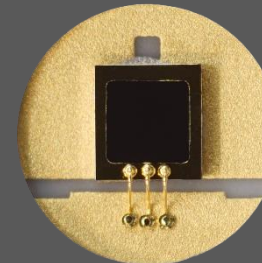
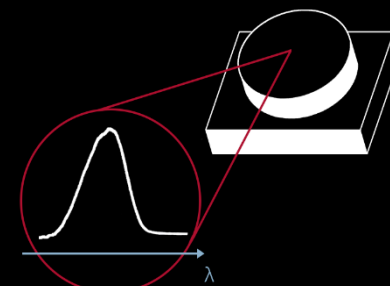

## more...

- Custom Packaging
- Collimation
- Technology Development
- Lithography Service

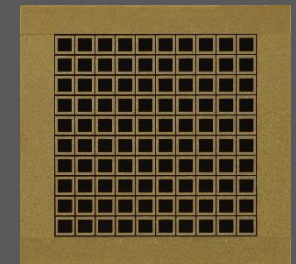

# Superluminescent Diode

→ SLD: 760 nm ... 2900 nm

- high power
- broadband
- custom specific solutions for every wavelength
- small footprint
- various packaging options w/wo TEC and NTC

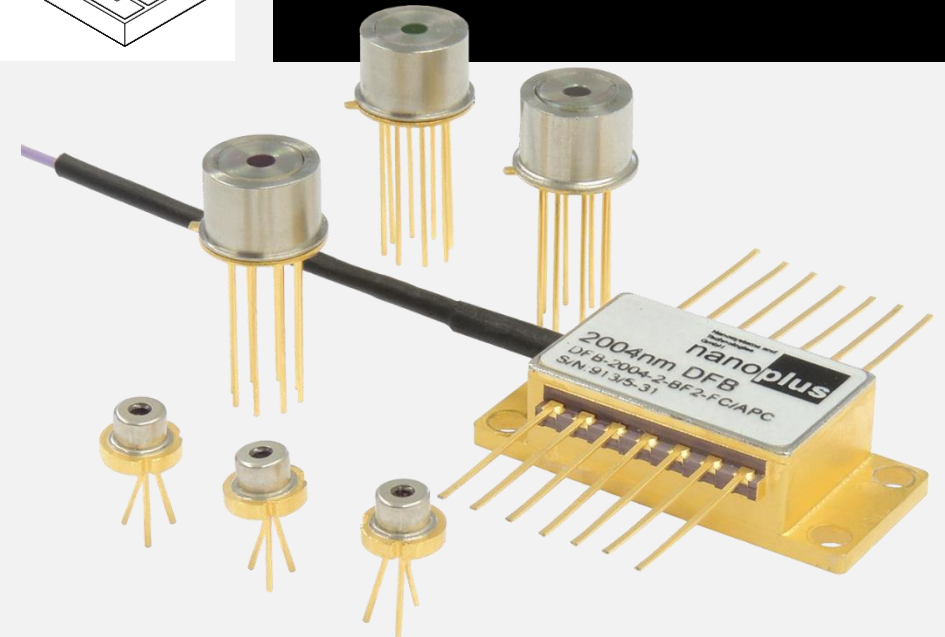
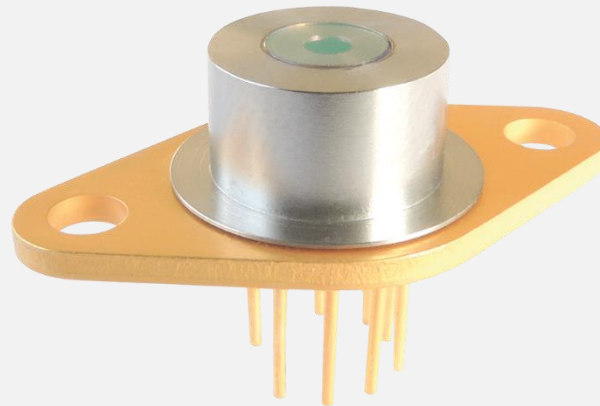
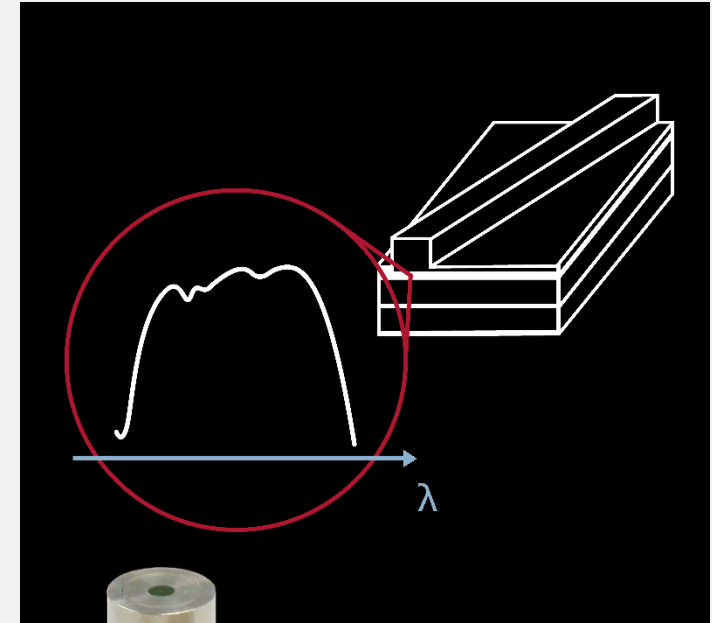
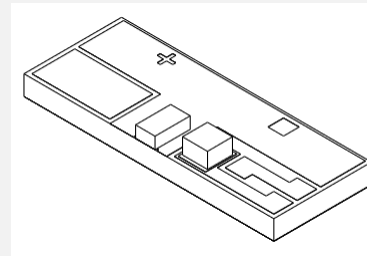

## DFB Laser

- wavelengths:  
760 nm – 14.000 nm  
(DL, ICL, QCL)
- custom specific solutions

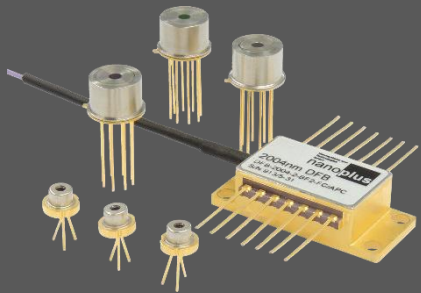
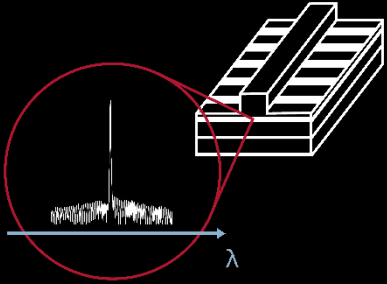

## Fabry-Pérot LD

- wavelengths:  
760 nm – 14.000 nm
- up to 1 W cw

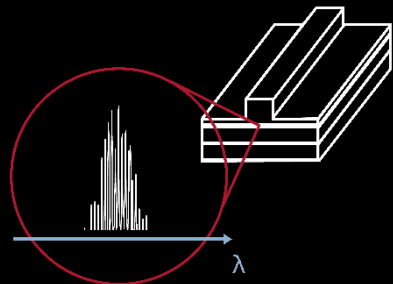

## SLD

- wavelengths:  
760 nm – 2900 nm
- cw & RT

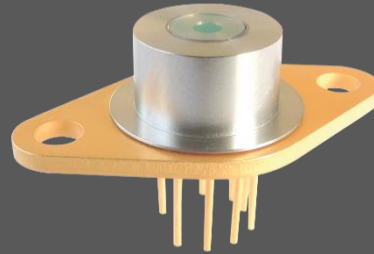
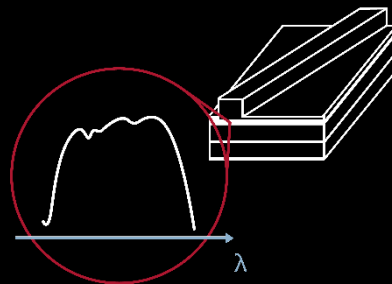

## MIR-LED

- wavelengths:  
2800 nm – 6500 nm
- cw & RT

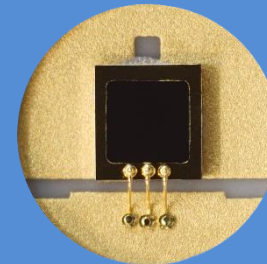
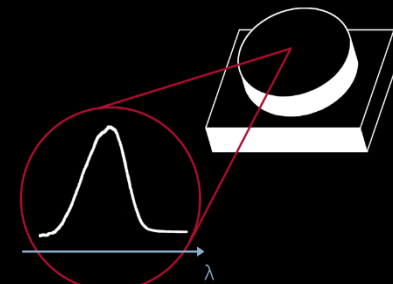

## more...

- Custom Packaging
- Collimation
- Technology Development
- Lithography Service

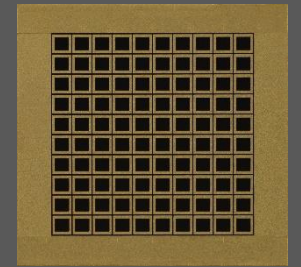

# MIR-LED

→ Mid InfraRed (Interband Cascade) LED: 2800 nm ... 6500 nm

true cw operation at RT  
high-power > 1mW @ low power consumption  
customer-specific solutions for every wavelength  
various packaging options w/wo TEC and NTC

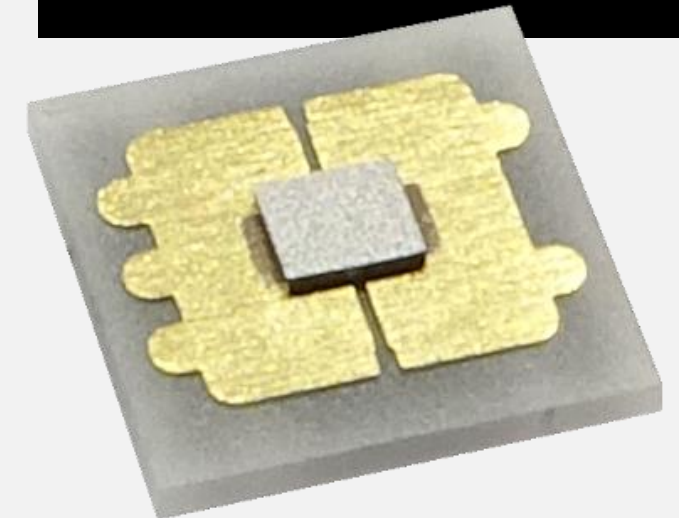
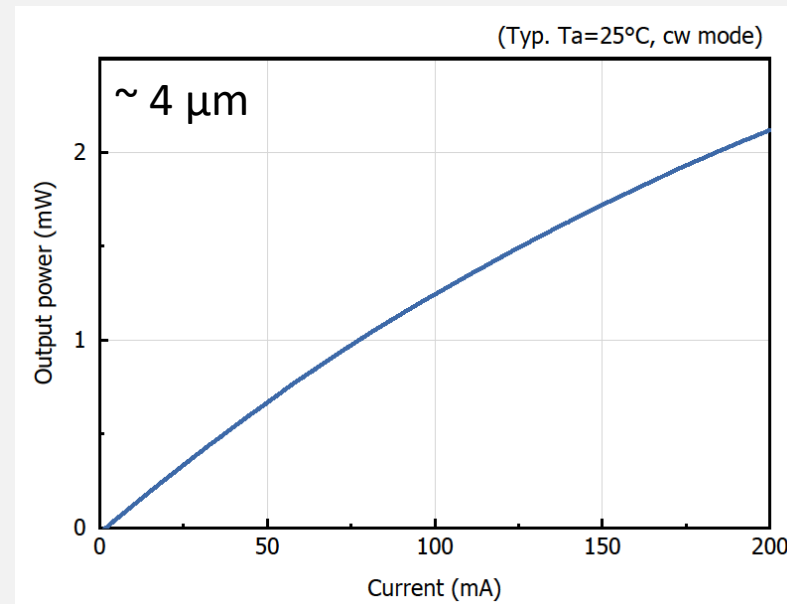
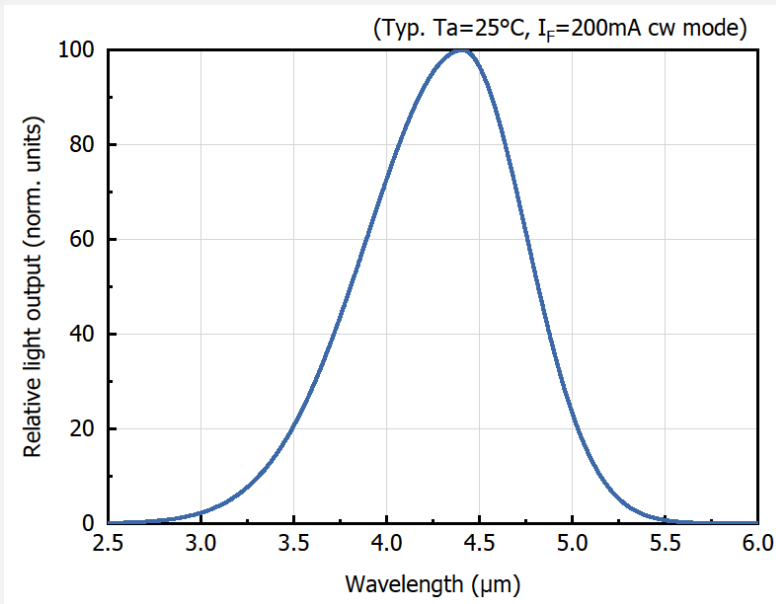
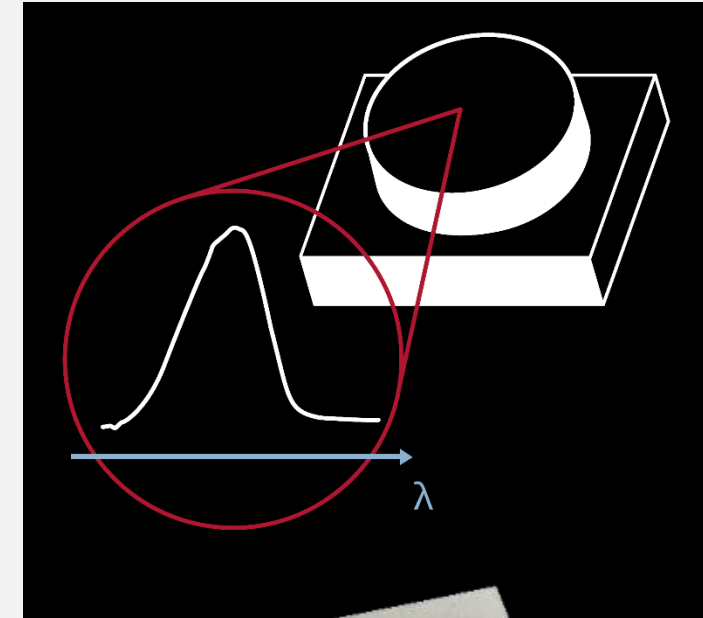

Nanosystems and  
Technologies  
GmbH

**nanoplus**

# EPIC Online Technology Meeting on Mid-IR Technologies for Environmental Monitoring

  
**Sensalight  
Technologies**



**2021**

**Dr. Johannes Koeth, CEO**  
nanoplus GmbH  
Nanosystems and Technologies  
Oberer Kirschberg 4  
D-97218 Gerbrunn

