



EPIC Online Technology Meeting on Growing Needs for Ultrafast, High Power Laser Applications

<https://Fluence.technology/>

Dr. Dariusz Świerad
Business Development Manager

13 January 2021

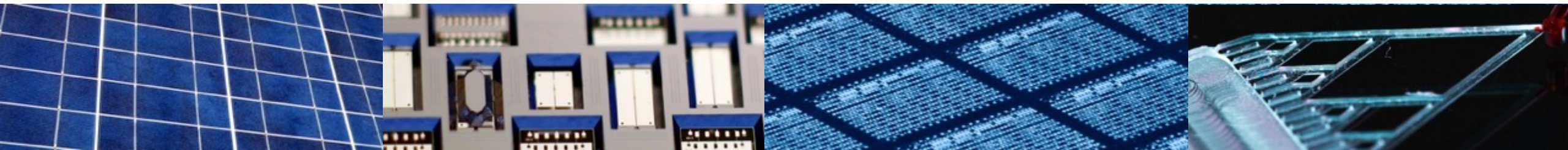

Experience

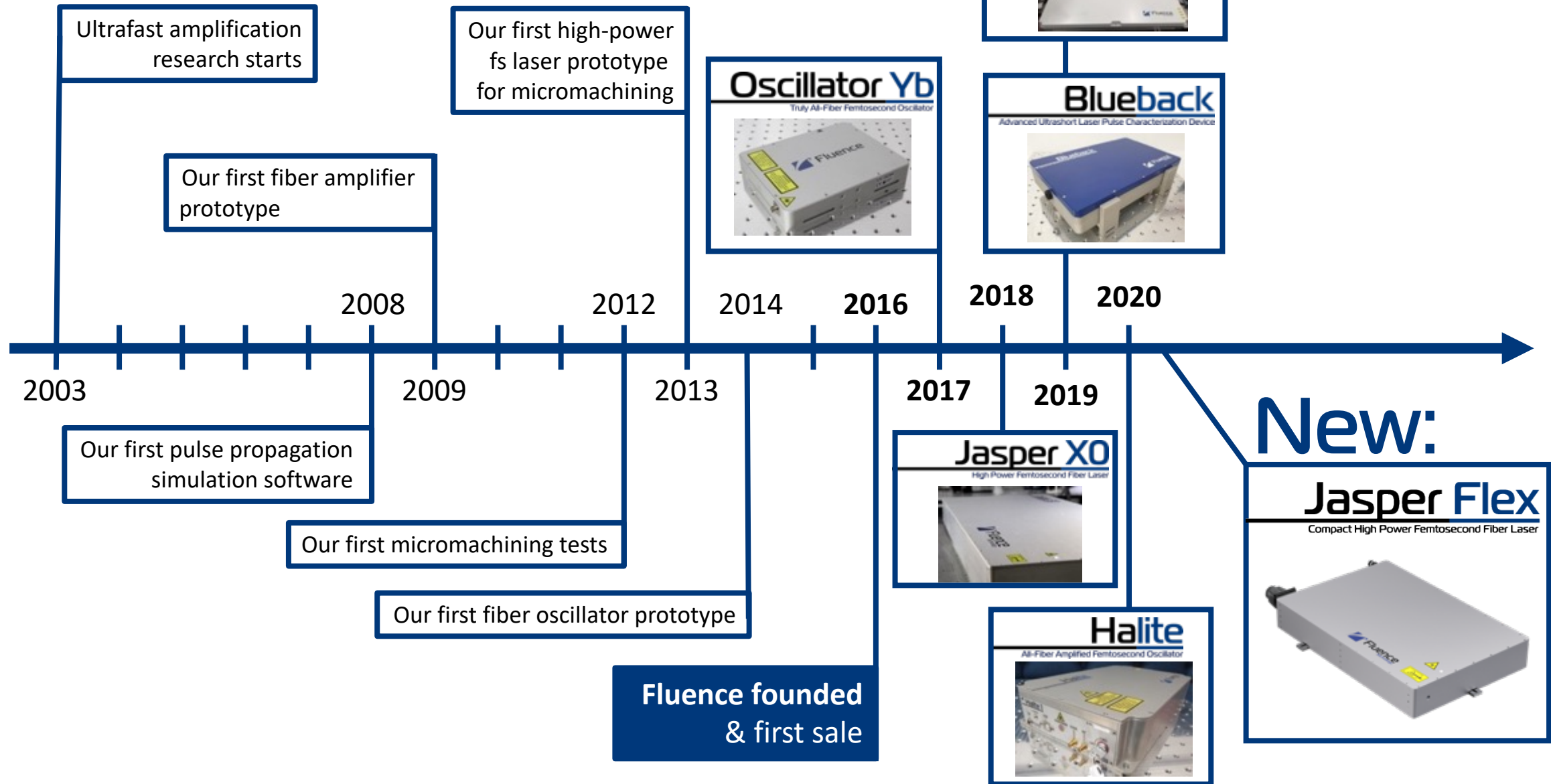

Fluence fs lasers at 1030 nm

Oscillator Yb
Truly All-Fiber Femtosecond Oscillator



20 mW
1 nJ

Halite
All-Fiber Amplified Femtosecond Oscillator



2 W
100 nJ

New

Jasper Flex
Compact High Power Femtosecond Fiber Laser

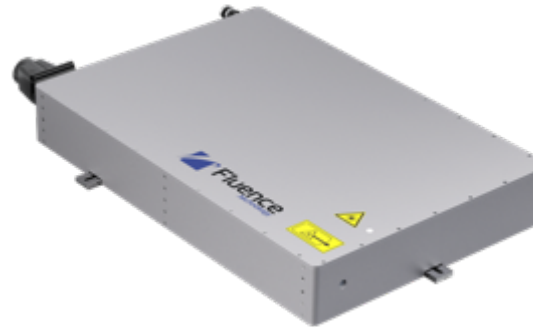

30 W
30 μ J

Most powerful and versatile

Jasper XO
High Power Femtosecond Fiber Laser



Average power: **60 W**
Max. Energy: **100 μ J** (200 μ J)
Max. Peak Power: **0.5 GW**
Pulse duration: **<250 fs**

Jasper XO

High Power Femtosecond Fiber Laser

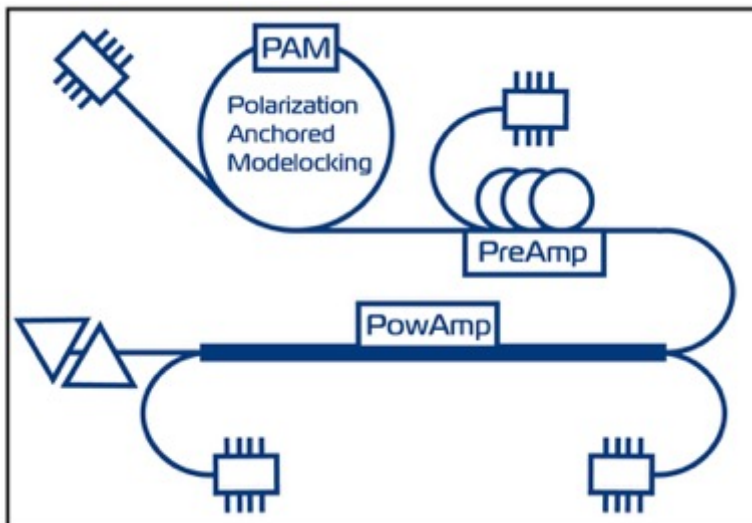

Highlights:

- Fiber construction
- SHG @515 nm,
THG @343 nm,
FHG @258 nm
harmonic options available
- Burst mode included
- Excellent lifetime,
- No SESAM
- No regular servicing required
- Stable average power level
- Best quality and parameters
within the high power fiber
femtosecond lasers*

Applications:

- ✓ Micromachining
- ✓ Athermal material processing
- ✓ Precise cutting
- ✓ Surface structuring
- ✓ Cold ablation
- ✓ Ophthalmology
- ✓ Ultrafast science
- ✓ **Prototyping**

13 January 2021,

EPIC Online Technology Meeting on
Growing Needs for Ultrafast, High Power Laser Applications,

Jasper X0

High Power Femtosecond Fiber Laser

High powers beyond 1030 nm

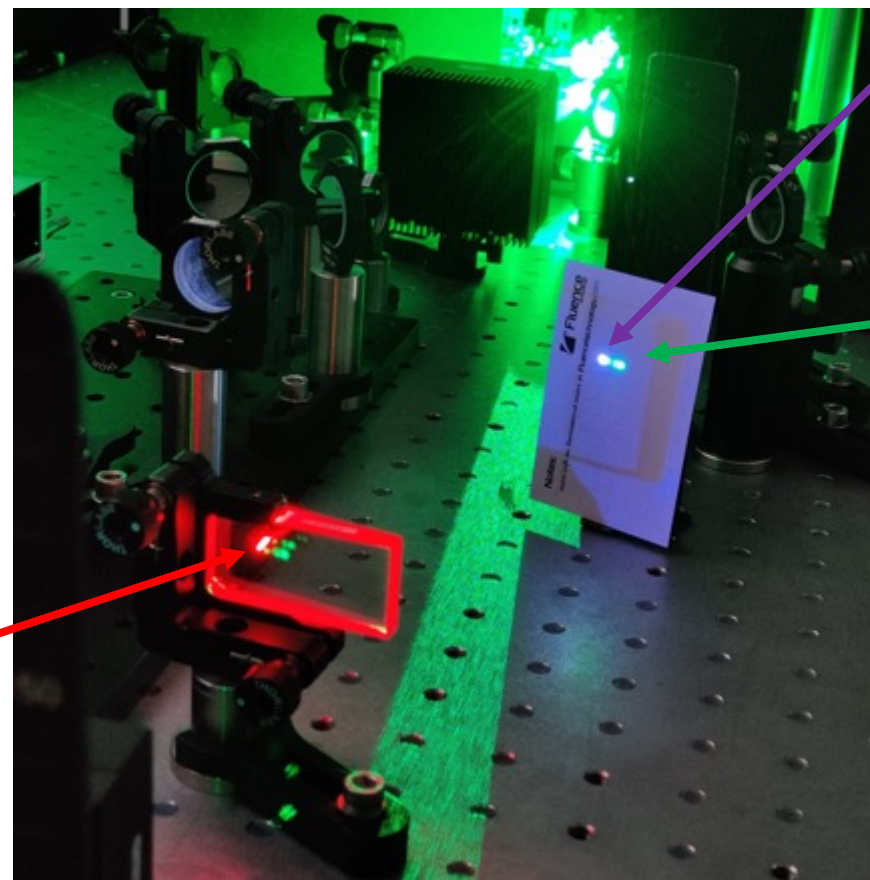

Fourth harmonic
258 nm

Second harmonic
515 nm

Excitation effects due to extreme light intensity in fused silica.

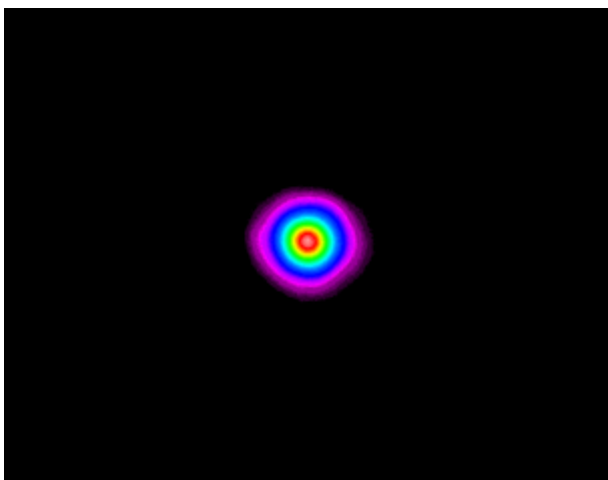
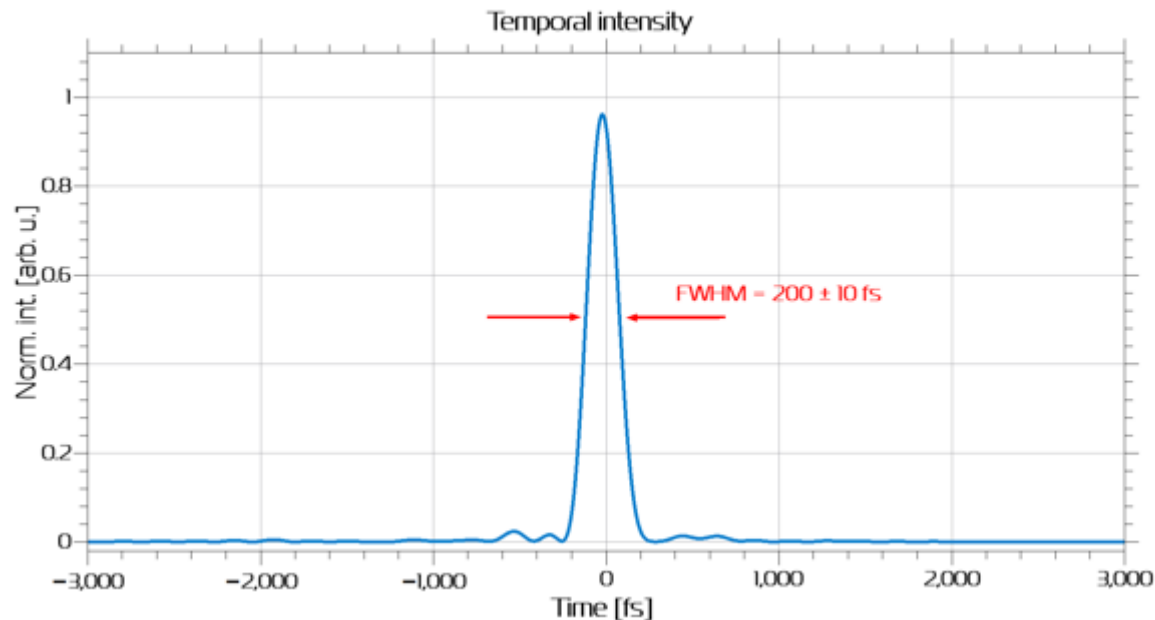
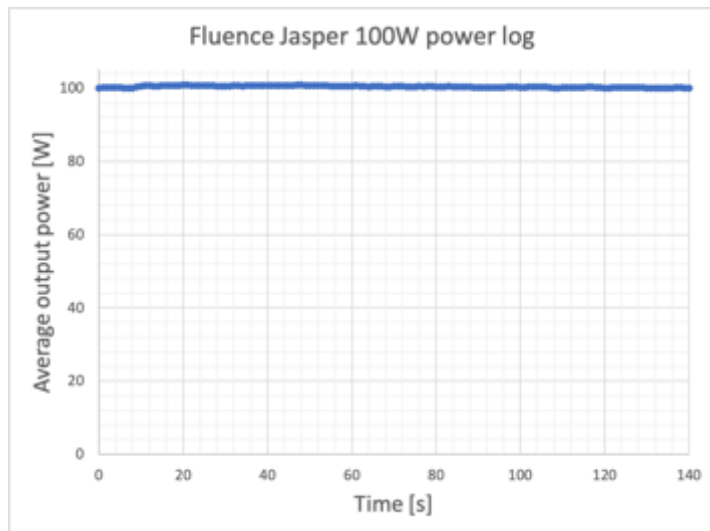

200 fs @ 100W,
 Fourier Transform Limited,
 Strehl Ratio: **96%**
 M^2 : **<1.25**
Fiber construction

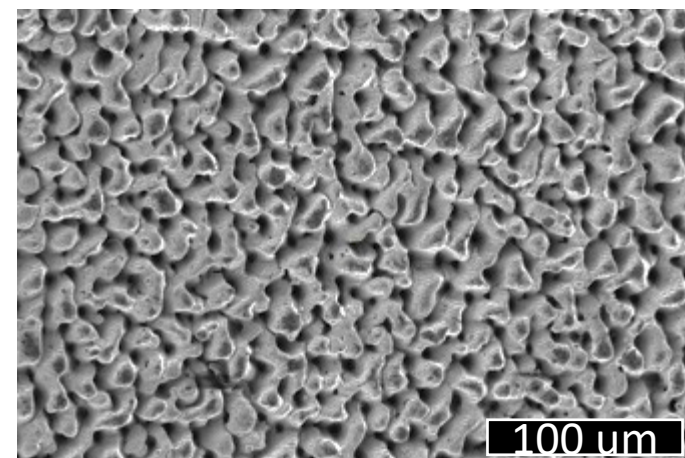
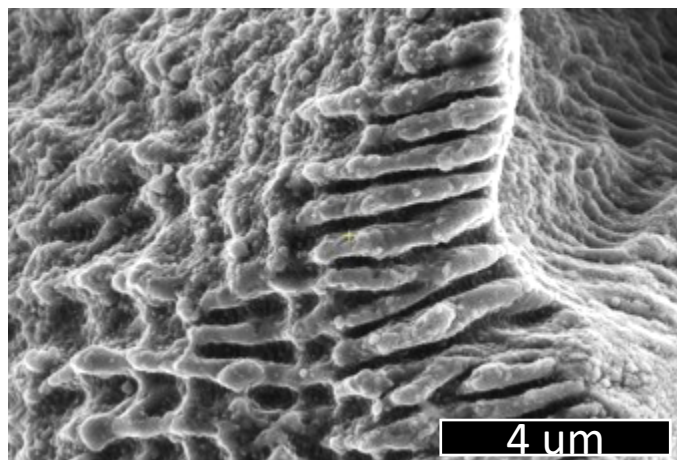
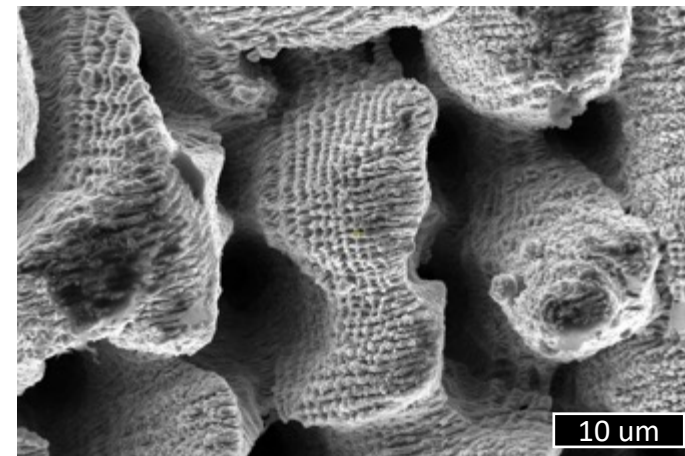
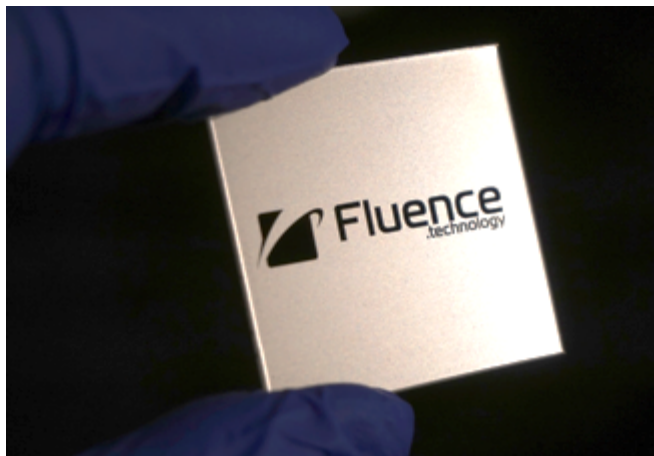

Fluence location

New application lab coming up



Headquarters in Warszawa,
Poland, EU

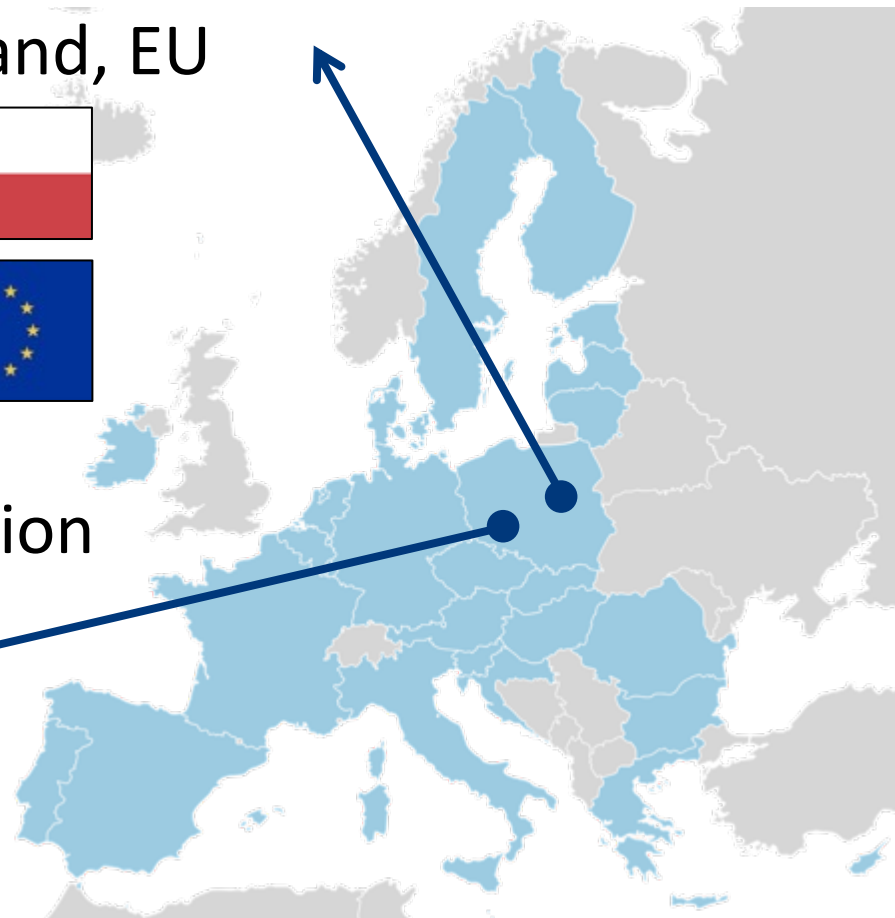

Soon new application
lab in Wrocław

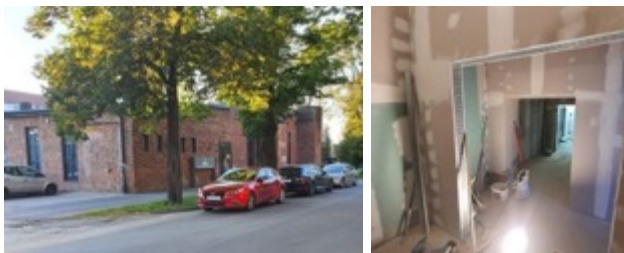
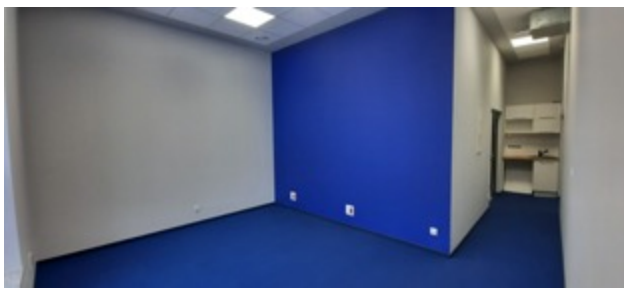



Thank you for your attention

<https://Fluencetechnology.com>
<https://Fluence.technology>